



ORIGINAL INSTRUCTIONS

TABLE OF CONTENTS

Welcome to Lumberjack!

Dear Customer, Congratulations on your purchase. Before using the product for the first time please be sure to read these instructions for use.

They provide you with all information necessary for using the product safely and to ensure its long service life.

Closely observe all safety information in these instructions!

General Power Tool Safety Warnings.....	01
Symbols & Cable Rating Chart	05
Machine Details and Product Features.....	06
Assembly.....	08
Operation.....	14
Working Advice.....	18
Maintenance and Service.....	19
Lumberjack Guarantee.....	21
Declaration of Conformity.....	23
Parts List.....	24
Parts Diagram.....	28

GENERAL POWER TOOL SAFETY WARNINGS

WARNING Read all safety warnings and all instructions. Failure to follow the warnings and instructions may result in electric shock, fire and/or serious injury.

Save all warnings and instructions for future reference. The term "power tool" in the warnings refers to your electric (corded) power tool or battery-operated (cordless) power tool.

1. Work area safety

a) Keep work area clean and well lit. Cluttered or dark areas invite accidents.

b) Do not operate power tools in explosive atmospheres, such as in the presence of flammable liquids, gases or dust. Power tools create sparks which may ignite the dust or fumes.

c) Keep children and bystanders away while operating a power tool. Distractions can cause you to lose control.

2. Electrical safety

a) Power tool plugs must match the outlet. Never modify the plug in any way. Do not use any adapter plugs with grounded power tools. Unmodified plugs and matching outlets will reduce risk of electric shock.

b) Avoid body contact with grounded surfaces, such as pipes, radiators, ranges and refrigerators. There is an increased risk of electric shock if your body is grounded.

c) Do not expose power tools to rain or wet conditions. Water entering a power tool will increase the risk of electric shock.

d) Do not abuse the cord. Never use the cord for carrying, pulling or unplugging the power tool. Keep cord away from heat, oil, sharp edges or moving parts. Damaged or entangled cords increase the risk of electric shock.

e) When operating a power tool outdoors, use an extension cord suitable for outdoor use. Use of a cord suitable for outdoor use reduces the risk of electric shock.

f) If operating a power tool in a damp location is unavoidable, use a residual current device (RCD) protected supply. Use of an RCD reduces the risk of electric shock.

3. Personal safety

a) Stay alert, watch what you are doing and use common sense when operating a power tool. Do not use a power tool while you are tired or under the influence of drugs, alcohol or medication. A moment of inattention while operating power tools may result in serious personal injury.

b) Use personal protective equipment. Always wear eye protection. Protective equipment such as dust mask, non-skid safety shoes, hard hat, or hearing protection used for appropriate conditions will reduce personal injuries.

c) Prevent unintentional starting. Ensure the switch is in the off position before connecting to power source and/or battery pack, picking up or carrying the tool. Carrying power tools with your finger on the switch or energising power tools that have the switch on invites accidents.

d) Remove any adjusting key or wrench before turning the power tool on. A wrench or a key left attached to a rotating part of the power tool may result in personal injury.

GENERAL POWER TOOL SAFETY WARNINGS

e) Do not overreach. Keep proper footing and balance at all times. This enables better control of the power tool in unexpected situations.

f) Dress properly. Do not wear loose clothing or jewellery. Keep your hair, clothing and gloves away from moving parts. Loose clothes, jewellery or long hair can be caught in moving parts.

g) If devices are provided for the connection of dust extraction and collection facilities, ensure these are connected and properly used. Use of dust collection can reduce dust-related hazards.

4. Power tool use and care

a) Do not force the power tool. Use the correct power tool for your application. The correct power tool will do the job better and safer at the rate for which it was designed.

b) Do not use the power tool if the switch does not turn it on and off. Any power tool that cannot be controlled with the switch is dangerous and must be repaired.

c) Disconnect the plug from the power source and/or the battery pack from the power tool before making any adjustments, changing accessories, or storing power tools. Such preventive safety measures reduce the risk of starting the power tool accidentally.

d) Store idle power tools out of the reach of children and do not allow persons unfamiliar with the power tool or these instructions to operate the power tool. Power tools are dangerous in the hands of untrained users.

e) Maintain power tools. Check for misalignment or binding of moving parts, breakage of parts and any other condition that may affect the power tool's operation. If damaged, have the power tool repaired before use. Many accidents are caused by poorly maintained power tools.

f) Keep cutting tools sharp and clean. Properly maintained cutting tools with sharp cutting edges are less likely to bind and are easier to control.

g) Use the power tool, accessories and tool bits etc. in accordance with these instructions, taking into account the working conditions and the work to be performed. Use of the power tool for operations different from those intended could result in a hazardous situation.

5. Service

a) Have your power tool serviced by a qualified repair person using only identical replacement parts. This will ensure that the safety of the power tool is maintained.

b) If the replacement of the supply cord is necessary, this has to be done by the manufacturer or its agent in order to avoid a safety hazard.

GENERAL POWER TOOL SAFETY WARNINGS

6. Additional Safety and Working Instructions

a) Dusts from materials such as lead-containing coatings, some wood types, minerals and metals can be harmful to one's health and cause allergic reactions, leading to respiratory infections and/or cancer. Materials containing asbestos may only be worked by specialists. Observe the relevant regulations in your country for the materials to be worked.

b) Prevent dust accumulation at the workplace. Dusts can easily ignite.

7. Additional Safety Warnings for Table Saws

a) Never stand on the power tool. Serious injuries can occur when the power tool tips over or when inadvertently coming into contact with the saw blade.

b) Take care that the blade guard operates properly and can move freely. Always adjust the blade guard in such a manner that it faces loosely against the work piece when sawing. Never clamp the blade guard when it is open.

c) Never reach behind the saw blade in order to hold the work piece, remove saw dust/wood chips or for any other reason. The clearance of your hand to the rotating saw blade is too small.

d) Guide the work piece against the saw blade only when the machine is switched on. Otherwise there is damage of kickback, when the saw blade becomes wedged in the work piece.

e) Keep handles dry, clean, and free from oil and grease. Greasy, oily handles are slippery causing loss of control.

f) Operate the power tool only when the work area to the work piece is clear of any adjusting tools, wood chips, etc. Small pieces of wood or other objects that come in contact with the rotating saw blade can strike the operator with high speed.

g) Only saw one work piece at a time. Work pieces placed on top or aside of each other can cause the saw blade to jam or the work pieces to move against each other while sawing.

h) Always use the parallel guide or the angle guide. This improves the cutting accuracy and reduces the possibility of saw blade binding.

i) Use the machine for grooving or rebating only with an appropriately suitable protective device (e. g. a tunnel blade guard).

j) Do not use the machine for cutting slots (stopped grooves).

k) Use the machine only for cutting the materials listed under Intended Use. Otherwise, the machine can be subject to overload.

GENERAL POWER TOOL SAFETY WARNINGS

l) If the saw blade should become jammed, switch the machine off and hold the work piece until the saw blade comes to a complete stop. To prevent kickback, the work piece may not be moved until after the machine has come to a complete stop. Correct the cause for the jamming of the saw blade before restarting the machine.

m) Do not use dull, cracked, bent or damaged saw blades. Unsharpened or improperly set saw blades produce narrow kerf causing excessive friction, blade binding and kickback.

n) Always use saw blades with correct size and shape (diamond versus round) of arbor holes. Saw blades that do not match the mounting hardware of the saw will run eccentrically, causing loss of control.

o) Do not use high speed steel (HSS) saw blades. Such saw blades can easily break.

p) Do not touch the saw blade after working before it has cooled. The saw blade becomes very hot while working.

q) Never operate the machine without the insert plate. Replace a defective insert plate. Without flawless insert plates, injuries are possible from the saw blade.

r) Check the cable regularly and have a damaged cable repaired only through an authorised customer service agent. Replace damaged extension cables. This will ensure that the safety of the power tool is maintained.

s) Store the machine in a safe manner when not being used. The storage location must be dry and lockable. This prevents the machine from storage damage, and from being operated by untrained persons.

s) Never leave the machine before it has come to a complete stop. Cutting tools that are still running can cause injuries.

t) Never use the machine with a damaged cable. Do not touch the damaged cable and pull the mains plug when the cable is damaged while working. Damaged cables increase the risk of an electric shock.

8. Using an Extension Cable.

a) If an extension cable is required, use an approved triple core extension cable suitable for the power input of the tool.

b) Grounded tools always require a three wire extension cable.

c) As the distance from the supply outlet increases you must use a heavier gauge extension cable. Using extension cables with inadequately sized wire causes a serious drop in voltage, resulting in loss of power and possible tool damage.

d) The smaller the gauge number of the wire the greater the capacity of the cord.

e) When using a cable reel, always unwind the cable completely.

SYMBOLS AND POWER RATING CHART



Danger! – Read the operating instructions to reduce the risk of injury.



Caution! Wear safety goggles.



Caution! Wear ear defenders. The impact of noise can cause damage to hearing.



Caution! Risk of Injury! Do not reach into the running saw blade.



Caution! Wear a dust mask.

MACHINE DETAILS AND PRODUCT FEATURES

Machine Details

Specifications:

Mains Voltage -	230V / 50Hz
Power Consumption -	2000W
No Load Speed -	4800rpm
Blade Spec -	254x30mm
Cutting Capacity:	
At 90 degrees -	50mm
At 45 degrees -	75mm
Table Size -	560x560mm
Nett Weight -	30kg

Package Contents:

Circular saw bench
Saw blade
Push stick
Mitre Gauge
Parallel Guide Fence
Blade Wrench

Intended Use

The power tool is intended as a stationary machine for making straight lengthways and crossways cuts in wood.

The capacity of the power tool is designed for sawing hardwood and softwood.

The power tool is not suitable for cutting aluminium or other non-ferrous metals or alloys.

Product Features

1. Saw Blade Protector
2. Fence
3. Extension table
4. Bench Inlay
5. Locking handle for extension table
6. Leg stand locking knob
7. Mitre fence
8. Mitre gauge
9. Blade bevel adjustment lock
10. On/Off Switch
11. Transportation wheels
12. Leg stand
13. Blade elevation handle

PRODUCT FEATURES

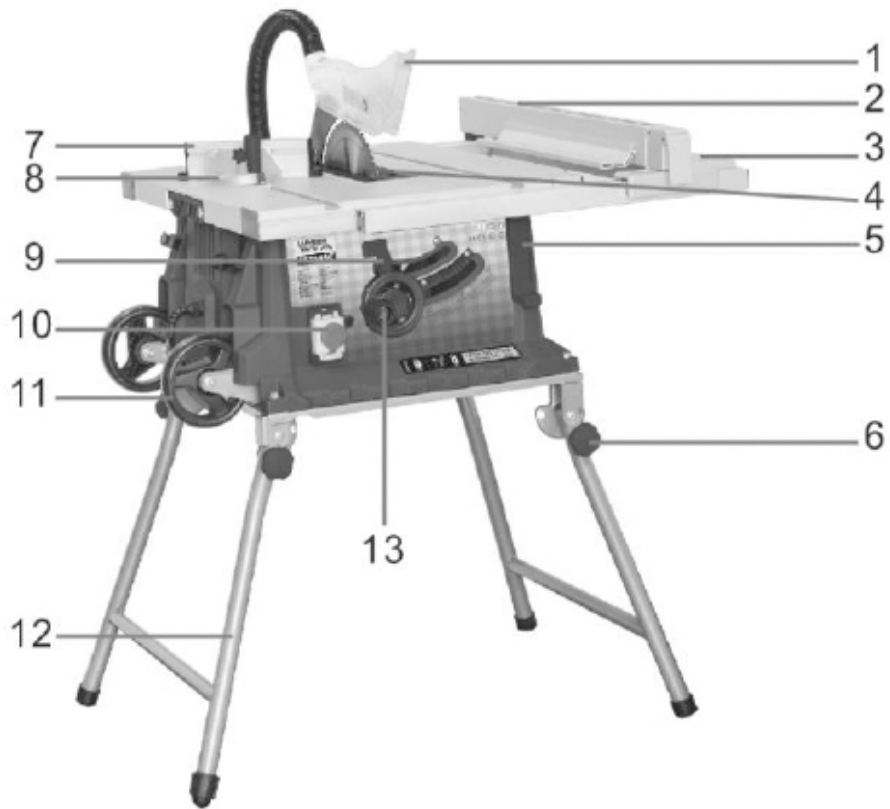

Assembly Instructions

Assembly

Avoid unintentional starting of the machine. During assembly and for all work on the machine, the power plug must not be connected to the mains supply.

Carefully remove all parts included in the delivery from their packaging.

Remove all packaging material from the machine and the accessories provided.

Before starting the operation of the machine for the first time, check if all parts listed in the box content list have been supplied

Note: Check the power tool for possible damage. Before further use of the machine, check that all protective devices are fully functional. Any lightly damaged parts must be carefully checked to ensure flawless operation of the tool. All parts must be properly and all conditions fulfilled to ensure faultless operation.

Damaged protective devices and parts must be immediately replaced by an authorised service centre.

Dust extraction

Dusts from materials such as lead-containing paint, some types of wood, minerals and metal maybe harmful to health. Touching or inhaling the dusts can cause allergic reactions and/or ailments of the respiratory tract of the user or persons in the vicinity. Certain dusts such as oak or beech dust are considered carcinogenic, particularly in combination with wood treatment additives (chromate, wood preservatives).

Materials containing asbestos may only be processed by experts.

- Always use a dust extraction facility.
- Make sure the workplace is well ventilated.
- Always wear a dust protection mask.
- Observe the regulations valid in your country for the materials to be processed.

Setting up the stand

There are three positions on the machine for different use, standing, folding and transporting. The legs are locked using twist knobs which lock/unlock in either direction and have a central unlocked position.

- Start with the saw standing on its wheels (A1), Unlock the upper legs. Swing up the legs and lock (A2) then unlock the lower legs.

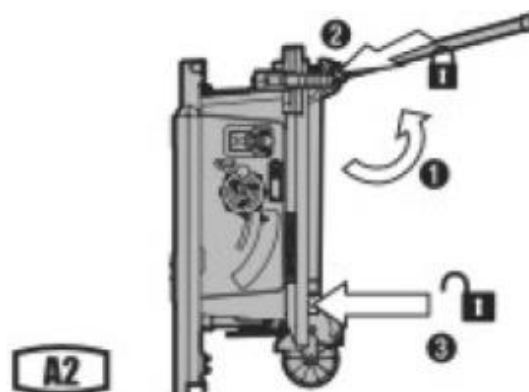
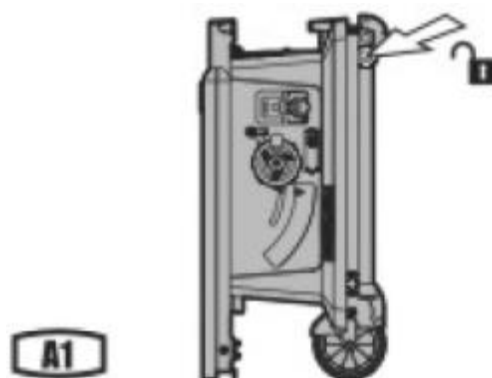

Assembly Instructions

– Lift the table from the end (A3), allowing the lower leg to swing into place. Swing the leg to fully into place and lock (A4).

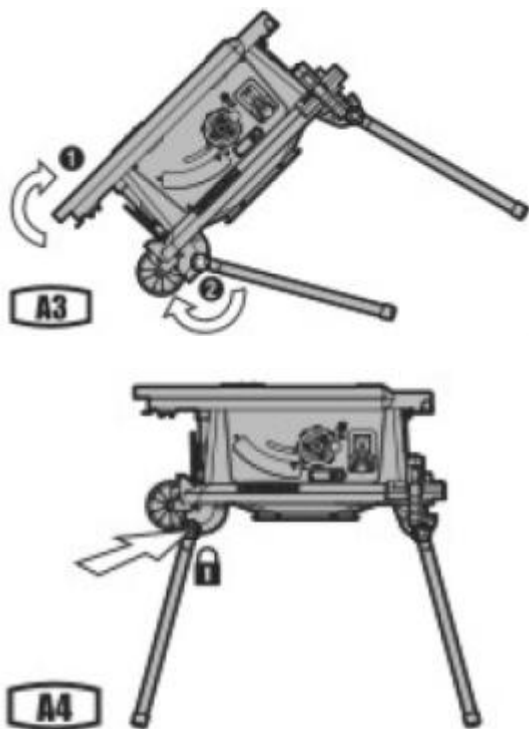

– There is a adjustable spring leg as shown in Fig. A5. You can rotate it clockwise or anticlockwise for your desired length. (A5)



Folding instructions

Hold and support the table edge, unlock the legs at the wheel end (B1). Lower the wheels to the ground, allowing the legs to swing under (B2). Stand the table on end, fold up and lock the lower legs, unlock the upper legs (B3). Swing down the legs and lock (B4).

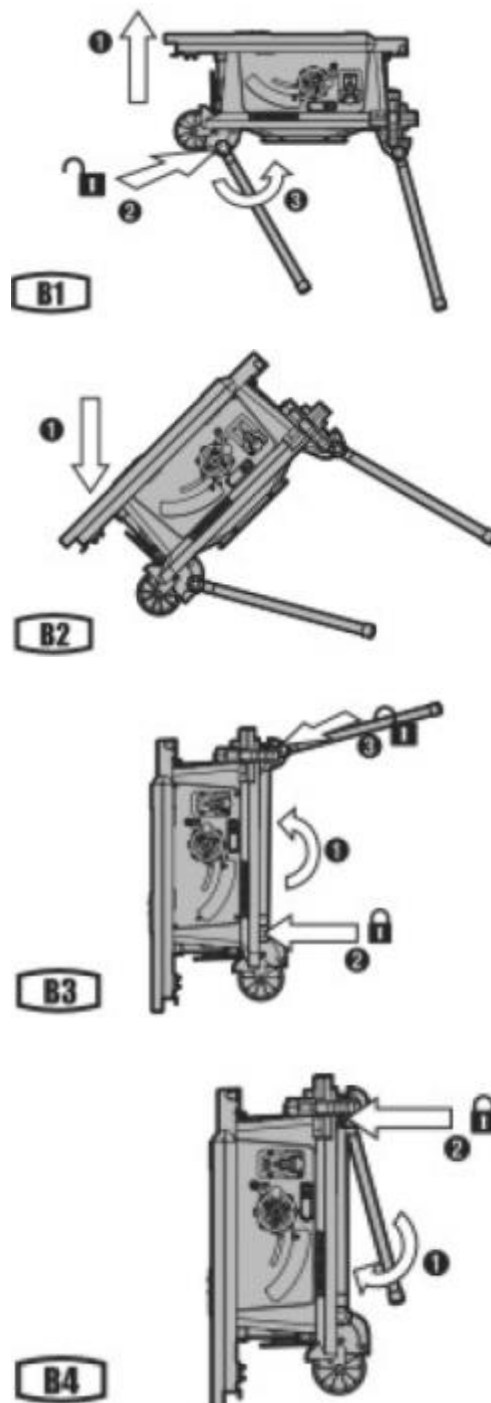

Assembly Instructions

To transport the table saw

The upper legs may be locked in the vertical position for use as a trolley handle.

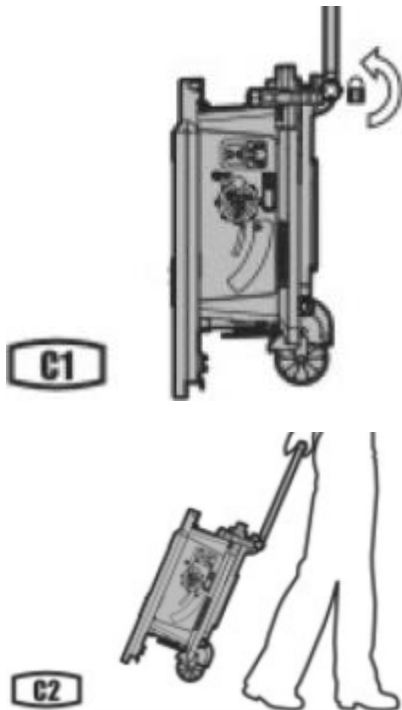

Adjusting the splitter

The splitter(14) has two positions: storage position (Fig. D1) and working position (Fig. D2). The splitter is in the storage position when you take it out of the package.

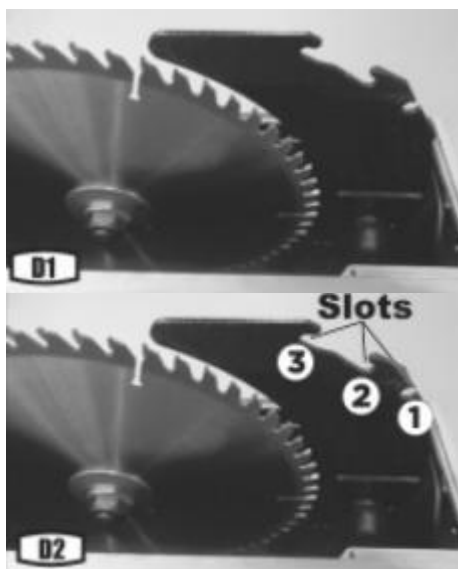

To place the splitter in the working position:

- Remove the blade throat plate.
- Raise the blade up to the highest position by turning the blade control wheel counterclockwise. Set the bevel at 0°. Make sure the bevel is locked tight.
- Release the splitter locking lever by pulling the lever up.
- Pull the splitter up to the working position holes should align with the two pins on the fixture.
- Lock the splitter by pushing the splitter locking lever down.

NOTE: Make sure the splitter is locked securely.

- Place the blade throat plate back on.

To adjust the splitter to be in the storage position:

Repeat steps 1 to 3 described above and slide the splitter down to the storage position. Lock the splitter locking lever. Lower the blade to the lowest position. The splitter should be under the saw table.

To adjust the height of the splitter

Loosen the two screws (a). Adjust the two adjusting screws to make sure the splitter is about 1/8" (3mm) above the blade tips. Tighten the two screws again.

Assembly Instructions

To adjust the alignment of the splitter

WARNING: To prevent personal injury, always unplug the saw from the power source before making any adjustments.

The splitter must be precisely IN LINE with the saw blade. Loosen the two screws (a), align the splitter with the saw blade. Once aligned, hold the splitter.



Assembling the Protective Cover

– Place protective cover (1) above the splitting wedge (14), so that the screw fits into the slit of the splitting wedge.

– Push the Protective cover (1) in to the bottom of the opening.



Adjusting the extension table and extension rail

The extension table can be opened and closed by the locking handle (5).

When the locking handle is in the “DOWN” position the extensions table is locked in place (see Fig. G1).

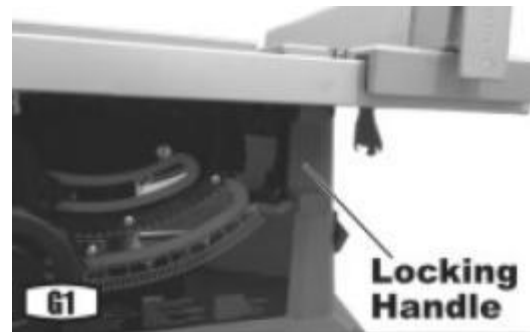

When the locking handle is in the “UPPER” position the extensions table is free to be adjusted (See Fig. G2).



Open the extension table when you need (See Fig. G3).



Assembly Instructions

When the extension table is in the desired position, the locking handle is in the "DOWN" Position(See Fig. G4).



NOTE: Make sure the locking handle is locked securely.

Screw the stopper on the extension rails (See Fig. G5)



Elevating & lowering handle

Mount the blade elevation handle (13) on the wheel by tightening the nut in the handle.



Mounting the rip fence

Release the locking handle by pulling it upward. Mount the rip fence onto the table so that the side with the indicator is on the scale side of the table (See Fig. I1).

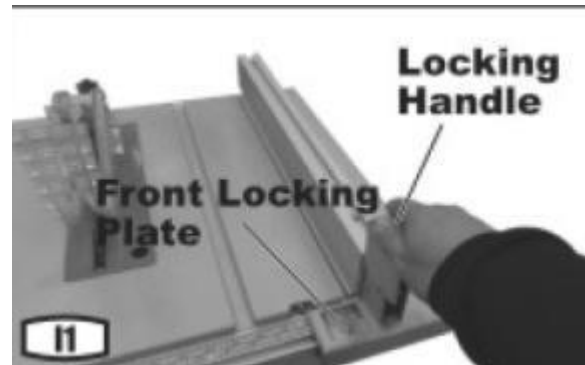

Start by sliding the front of the rip fence onto the front side of the table so that the front locking plate contacts the front side of the table then push down on the back of the rip fence so that the fence is level on the table. Be sure front and rear locking plates are in contact with both the front and back edges of the table.(See Fig.I2)

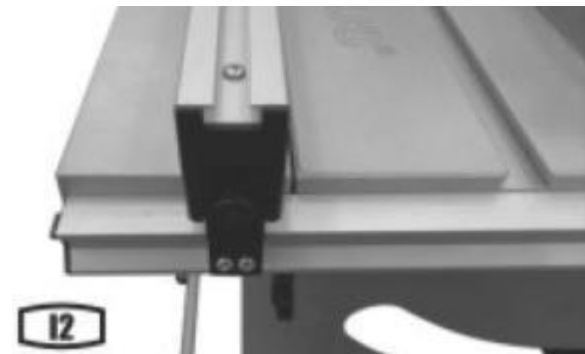

Unclipping the rip fence

Release via the locking handle

Assembly Instructions

Adjustment of the rip fence

The rip fence has been adjusted at the factory to be at 90° angle to the front side of the table. If it is not at a 90° angle to the table, loosen the two bolts (b) at the top front side of the rip fence with supplied allen key and adjust the rip fence angle so it is at a 90° angle. (See Fig. J1)

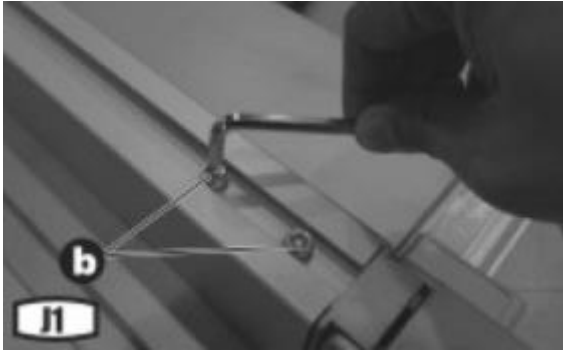

Move the Rip fence to contact the side of the blade (the zero point) and then check that the rip fence position indicator is on the "0" mark on the scale. If it is not, loosen the screw (c) and position the indicator on "0" and then retighten the screw. (See Fig. J2)

NOTE: The Blade Guard and splitter will need to be removed to perform this adjustment.

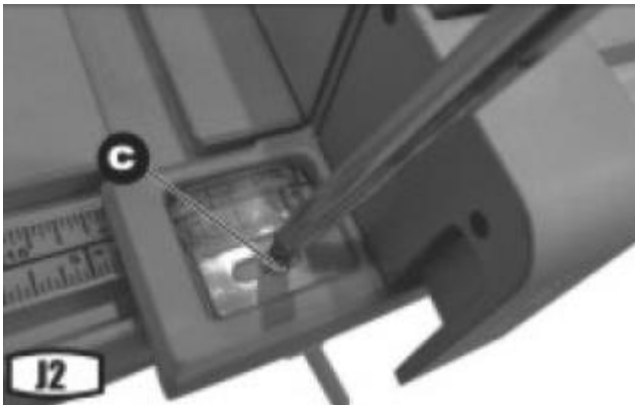

OPERATION

Operation

On-Off switch

- Switch on = press green switch [1].
- Switch off = press red switch [0].

Blade elevation handle

The blade elevation handle (13) is used to raise and lower the saw blade. Rotate blade elevation handle clockwise to lower the blade and counter-clockwise to raise it (See Fig. L)



Blade tilting wheel

The blade tilting wheel (15) is used to tilt the saw blade for bevel cutting

The blade bevel adjustment lock (9) holds the beveling mechanism in the desired position.

When setting the angle of the cut, loosen the blade bevel scale. Set the blade at the desired angle. Tighten the blade bevel adjustment lock by turning it clockwise. Before turning the table saw "ON", be sure all adjustments are securely tightened to prevent the blade from shifting during operation.

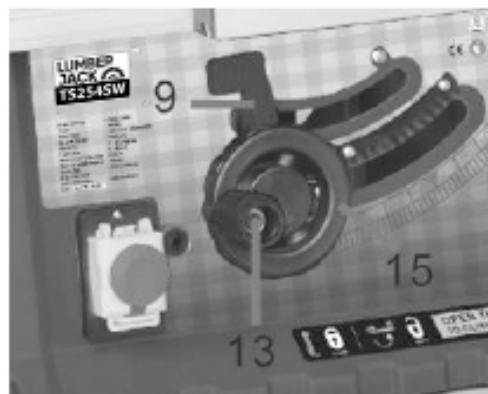

The splitter

The splitter (14) separates the two pieces of wood that result after the work-piece is pushed through the saw blade. The splitter prevents binding and kickback.

Rip fence

This rip fence is used for all ripping operations. Never rip freehand without the fence in place and securely locked.

Mitre gauge

The mitre gauge (5) is used for performing cross cuts and mitre cuts and mitre cuts. The gauge head is locked in the desired position by tightening the locking handle (a). Always ensure the locking handle is securely fastened before starting a cut. To adjust the mitre gauge angle, loosen mitre gauge locking handle and rotate the mitre gauge body so that the "0" mark on the end of the sliding bar points to desired position, then tighten the locking handle. To adjust the mitre fence, loosen the locking knob (b) and slide the mitre fence to the desired position. Then tighten the locking knob.

NOTE: The mitre gauge body has marks at 5-degree increments. The sliding bar has marks at 1-degree increments. Read both to get an accurate angle degree.

OPERATION

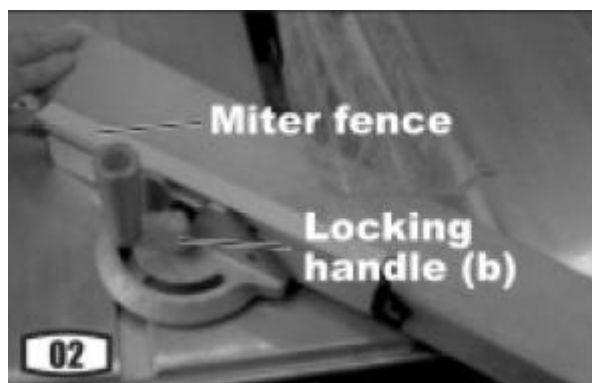
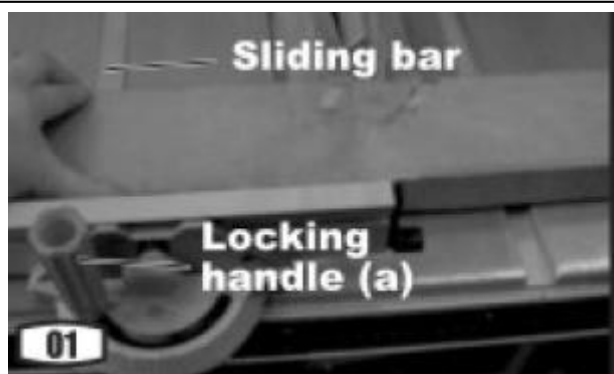

Push stick

The device used to feed the work-piece through the saw during narrow ripping cuts. The push stick helps to keep the operator's hands well away from the blade. Use the push stick for ripping widths less than 6" (150mm) and more than 2" (50mm).

Basic table saw operations

- When crosscutting, mitre cutting, bevel cutting, compound mitre cutting or rebating across the end of a narrow work-piece, use the mitre gauge.
- Never make these cuts freehand (not using the mitre gauge or other devices) because the blade could bind, causing a kickback or causing your hand or fingers to contact the blade.
- Always lock the angle of the mitre gauge when in use.
- Except for when making rip cuts, remove the rip fence from the table.
- Make sure the blade guard is mounted for all through sawing operations (the blade cuts through the entire thickness of the wood). Re-attach the guard immediately after finishing dado, molding or rebating cuts.
- The blade should extend approximately 1/8" (3mm) above the top of the work-piece.
- Use the push stick whenever you make a narrow cut.

Crosscutting

Crosscutting is cutting wood across the grain at 90° or square with both the edge and the flat side of the wood. This is done with the mitre gauge set at "0". Before using the mitre gauge, make sure it is locked. The mitre gauge can be used in either of the grooves in the table.

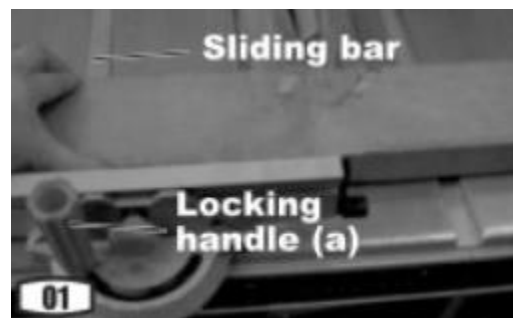

OPERATION

Mitre cross-cutting

Mitre cross-cutting is cutting the wood at an angle other than 90°. Follow the same procedures as you would for crosscutting. Adjust the mitre gauge to the desired angle.



Bevel cross-cutting

Bevel cross-cutting is the same as cross-cutting except that the blade is also set at an angle other than 90°. Adjust the blade to the desired angle using the blade tilting wheel.



Compound mitre cutting

Compound mitre cutting is a combination of mitre cutting and bevel crosscutting. The cut is made at an angle other than 90° to both the edge and the flat side of the wood. Adjust the mitre gauge and the blade bevel to the desired angle and be sure that the mitre gauge and blade bevel adjustment lock are locked.



Ripping

Ripping is cutting a piece of wood with the grain. This is done using the rip fence. Position the fence to the desired width of the rip cut and lock it in place. Before starting to rip, make sure:

1. The rip fence is parallel to the saw blade.
2. The splitter is properly aligned with the saw blade.

When ripping long boards or large panels, always use a work-piece support. Hold the material to be cut against the rip fence and feed it through the blade with smooth, steady pressure.

Only apply feed pressure to the work-piece between the blade and the rip fence in order to prevent the work-piece from binding against the blade and causing kickback.

When ripping boards narrower than 6" (150mm), use a push stick to feed the work-piece until it is clear of the table.

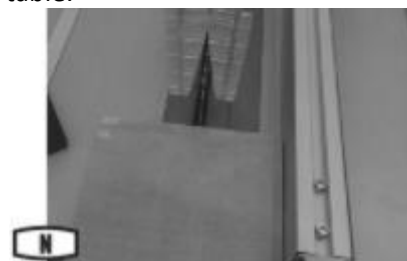

Bevel ripping

When bevel ripping material 6" (150mm) or narrower, use the rip fence on the right side of the blade only.



OPERATION

Sawdust collection

This table saw is equipped with a removable sawdust collector. A dust collection system (sold separately) can be attached to the dust port to help remove sawdust from the work area. To remove the sawdust collector, simply loosen two nuts and remove the collector from the saw.



Application cutting tips

1. Make sure the kerf is made on the scrap side of the measuring line.
2. Cut the wood with the finished side up.
3. Always have a proper support for the wood as it comes out of the blade.
4. Make a test cut for important cuts.
5. Always use the correct blade depth setting. The top of the blade teeth should clear the top of the material being cut by 1/8" (3mm) to 1/4" (6mm).
6. Inspect the work-piece for knots or nails before beginning a cut.
7. Always use clean, sharp, properly-set blades. Never make a cut with a dull blade.
8. When making a cut, use steady, even pressure. Never force a cut.
9. DO NOT cut wet or warped lumber.
10. Always hold your work-piece firmly with both hands or use a push stick or push block.

Working Advice

Working Advice

General Sawing Instructions

- For all cuts, it must first be ensured that the saw blade at no time can come in contact with the stops or other machine parts.
- Use the machine for grooving or rebating only with an appropriately suitable protective device (e. g. a tunnel blade guard).
- Do not use the machine for cutting slots (stopped grooves).

Protect the saw blade against impact and shock. Do not subject the saw blade to lateral pressure.

The riving knife must be in alignment with the saw blade to avoid jamming of the work piece.

Do not saw warped/bent work pieces. The work piece must always have a straight edge to face against the parallel guide.

Always keep/store the push stick with the power tool.

Position of the Operator

- Do not stand in a line with the saw blade in front of the machine. Always stand aside of the saw blade. This protects your body against possible kickback.
 - Keep hands, fingers and arms away from the rotating saw blade.
- Observe the following instructions:
- Hold the work piece securely with both hands and press it firmly against the saw table.
 - When sawing narrow work pieces and bevel angles, always use the supplied hold-down stick.

– Hold the work piece securely with both hands and press it firmly against the saw table.

– When sawing narrow work pieces and bevel angles, always use the supplied hold-down stick.

MAINTENANCE AND SERVICE

Maintenance and Service

Maintenance and Cleaning

Before any work on the Table Saw itself, pull the mains plug.

If the machine should fail despite the care taken in manufacturing and testing procedures, repair should be carried out by an approved service centre.

– Store the tool, instruction manual and accessories in a secure place. In this way you will always have all the information and parts on hand.

Changing the saw blade

WARNING: Always unplug the saw from the power source before maintenance to avoid risk of serious personal injury.

To remove the blade:

1. Remove the blade guard and the blade throat plate
2. Raise the blade to the highest possible position.
3. To keep the arbor from rotating, place the spanners on the flange flats.
4. Place the wrench on the arbor nut.
5. Turn the wrench clockwise to tighten, counterclockwise to loosen. Loosen and remove the arbor nut.
6. Remove the flange and pull the blade off the motor shaft.

To install the blade:

1. Install new blade onto motor shaft and assemble flange.
2. Turn the wrench clockwise to tighten the arbor nut.
3. Reassemble blade guard and the blade throat plate.

IMPORTANT: Blade rotation is clockwise when observing from the right side of the saw. Make sure the rotation direction mark on blade matches with that.



Cleaning

– For safe and proper working, always keep the power to land its ventilation slots clean.

– Remove dust and chips after each working procedure by blowing out with compressed air or with a brush.

TROUBLESHOOTING

Trouble	Probable cause	Remedy
Saw will not start	<ol style="list-style-type: none"> 1.Saw is not plugged in 2.Blown fuse or circuit breaker 3.Cord is damaged 4.Debris in ON/OFF switch 	<ol style="list-style-type: none"> 1.Plug into power source 2.Replace fuse or reset circuit breaker 3.Have power cord replaced by authorised service centre 4.Clean any accumulated
Does not make accurate 45° and 90° rip cuts	<ol style="list-style-type: none"> 1.Positive stop not adjusted 2.Blade angle pointer not set accurately 	<ol style="list-style-type: none"> 1.Check blade with square and adjust 2.Check blade with square and adjust blade angle pointer
Material pinched blade when ripping	<ol style="list-style-type: none"> 1.Rip fence is not aligned with blade 2.Warped wood, edge against fence is not straight 	<ol style="list-style-type: none"> 1.Check and adjust the rip fence 2.Select another piece of wood
Material binds on splitter	Splitter not correctly in line with blade	Check and align the splitter with blade
Saw makes unsatisfactory cuts	<ol style="list-style-type: none"> 1.Dull blade 2.Blade mounted backward 3.Gum or resin on blade 4.Incorrect blade for work 	<ol style="list-style-type: none"> 1.Replace blade 2.Turn blade around 3.Remove blade and clean 4.Change to correct blade
Material kicked back from the blade	<ol style="list-style-type: none"> 1.Rip fence is out of adjustment 2.Splitter is not in line with blade 3.Feeding stock without rip fence 4.Dull blade 5.Bevel knob is not tight 	<ol style="list-style-type: none"> 1.Align rip fence with mitre gauge groove 2.Align splitter with blade 3.Install and use rip fence 4.Replace blade 5.Tighten the knob
Blade does not raise or tilt freely	Sawdust and dirt in elevation/tilting	Brush or blow out loose dust and dirt
Blade does not come up to speed, reset trips too easily	<ol style="list-style-type: none"> 1.Extension cord is too light or too long 2.Low house voltage 	<ol style="list-style-type: none"> 1.Replace extension cord with adequate size 2.Contact electrician
Saw vibrates excessively	<ol style="list-style-type: none"> 1.Saw is not mounted securely to work bench 2.Bench or stand is on uneven floor 3. Damaged saw blade 	<ol style="list-style-type: none"> 1.Tighten all mounting hardware 2.Re-position on flat, level floor 3.Replace blade

LUMBERJACK GUARANTEE

1. Guarantee

1.1 Lumberjack guarantees that for a period of 12 months from the date of purchase the components of qualifying products (see clauses 1.2.1 to 1.2.8) will be free from defects caused by faulty construction or manufacture.

1.2. During this period Lumberjack, will repair or replace free of charge any parts which are proved to be faulty in accordance with paragraph 1.1 providing that:

1.2.1 You follow the claims procedure set out in clause 2

1.2.2 Lumberjack and its authorised dealers are given reasonable opportunity after receiving notice of the claim to examine the product

1.2.3 If asked to do so by Lumberjack or its Authorised dealer, you return the product at your own cost to Lumberjack's or supplying Authorised Dealer's premises, for the examination to take place clearly stating the Returns Material Authorisation number given by Lumberjack or an Authorised Dealer.

1.2.4 The fault in question is not caused by industrial use, accidental damage, fair wear and tear, wilful damage, neglect, incorrect electrical connection, misuse, or alteration or repair of the product without approval.

1.2.5 The product has been used in a domestic environment only

1.2.6 The fault does not relate to consumable items such as blades, bearings, drive belts, or other wearing parts which can reasonably be expected to wear at different rates depending on usage.

1.2.7 The product has not been used for hire purposes.

1.2.8 The product has been purchased by you as the guarantee is not transferable from a private sale.

2. Claims Procedure

2.1 In the first instance please contact the Authorised Dealer who supplied the product to you. In our experience many initial problems with machines that are thought to be faulty due to faulty parts are actually solved by correct setting up or adjustment of the machine. A good Authorised Dealer should be able to resolve the majority of these issues much more quickly than processing a claim under the guarantee. If a return is requested by the Authorised Dealer or Lumberjack, you will be provided with a Returns Material Authorisation number which must be clearly stated on the returned package, and any accompanying correspondence. Failure to provide a Returns Material Authorisation number may result in item being refused delivery at Authorised Dealer.

2.2 Any issues with the product resulting in a potential claim under the guarantee must be reported to the Authorised Dealer from which it was purchased within 48 hours of Receipt.

2.3 If the Authorised Dealer who supplied the product to you has been unable to satisfy your query, any claims made under this Guarantee should be made directly to Lumberjack. The Claim itself should be made in a letter setting out the date and place of purchase, giving a brief explanation of the problem which has led to the claim. This letter should be then sent with proof

LUMBERJACK GUARANTEE

of purchase to Lumberjack. If you include a contact number with this it will speed your claim up.

2.4 Please note that it is essential that the letter of claim reaches Lumberjack on the last day of this Guarantee at the latest. Late claims will not be considered.

3. Limitation of Liability

3.1 We only supply products for domestic and private use. You agree not to use the product for any commercial, business or resale purposes and we have no liability to you for any loss of profit, loss of business, business interruption or loss of business opportunity.

3.2 This Guarantee does not confer any rights other than these expressly set out above and does not cover any claims for consequential loss or damage. This Guarantee is offered as an extra benefit and does not affect your statutory rights as a consumer.

4. Notice

This Guarantee applies to all product purchased from an Authorised Dealer of Lumberjack within the United Kingdom. Terms of Guarantee may vary in other countries.

CE DECLARATION OF CONFORMITY

TOOLSAVE

Unit C, Manders Ind. Est.,
Old Heath Road, Wolverhampton,
WV1 2RP
Tel: 01902 450 470

Declares that the TABLE SAW (TS254SW)

Is in compliance with the regulations included in the Directives:2006/95/EC

EC DECLARATION OF CONFORMITY

Certificate for EC-type examination delivered by TÜV SÜD Product Service GmbH-Zertifizierstelle –
RIDLERSTRASSE 65-80339 München Germany (Registration No.: N8M 15 04 44390 937)

Person who declares: Bill Evans



24.09.2020

The Director

A handwritten signature in black ink, appearing to read 'Bill Evans', written over a light grey background.

Parts List

No.	Description	No.	Description
1	Outlet mouth	31	Screw
2	ST3.5x16 screw	32	Blade guard (right)
3	ST3.9x10 screw	33	Locking nut
4	Switch box cover	34	Screw
5	Overload switch	35	Riving knife
6	Inductance	36	Bolt
7	Capacitance	37	Right extension table
8	Switch box	38	Stopper B
9	Switch	39	Guide tube
10	M4x16 screw	40	Bolt
11	Label for body	41	Holder
12	M6 lock screw	42	Screw
13	Big hand wheel	43	Pointer
14	Ø6 big flat washer	44	Compress spring
15	Small handle	45	Screw B
16	Ø 8 flat washer	46	Friction pad
17	M6 screw	47	Stopper A
18	Angle location	48	Pin axis A
19	M5x14 screw	49	Clamping screw
20	Gear rack	50	Clamping block
21	M4x12 screw	51	Spring pin
22	M4x8 screw	52	Pin axis B
23	Pointer of body	53	Eccentric wheel
24	Ø4 spring	54	Handle body
25	M4 screw	55	Handle cover
26	M4x8 screw	56	Scale label
27	Machine body	57	Closure plate B
28	Foot washer	58	Front rail
29	Small label of body	59	Rotate bar(1)
30	Main working table	60	Rotate location block

Parts List

No.	Description	No.	Description
61	Ø5 big flat screw	91	6003 bearing
62	M6x16 screw	92	Spring steel piece
63	Ø6 spring	93	Angle clamp board
64	5x12 screw	94	Ø35 snap spring
65	Motor support board	95	Output axis
66	Output guard	96	Flat key5x5x12
67	M5x6 screw	97	Big gear wheel
68	Saw blade guard1	98	Ø16 shaft circlip
69	M6x20 screw	99	HK1210needle baring
70	Pressure block	100	Middle cover
71	Washer	101	M8 lock screw
72	Rotate support (2)	102	Ø4 washer
73	Rotate bar(2)	103	6202 bearing
74	Rotate location board	104	Screw bar
75	M6x12 screw	105	Rotor
76	M10 screw	106	629bearing
77	Ø10 flat washer	107	ST4.8x60 screw
78	Fasten location block	108	Stator
79	Saw blade guard2	109	Fan shroud
80	ST3.9x12 screw	110	Motor housing
81	Cover block	111	Brush holder
82	M14screw	112	Carbon brush
83	Outer pressure board	113	Brush holder cover
84	Saw blade	114	(Motor)connection
85	Clamp(2)	115	Cable plug
86	Push sticker	116	Cable plug
87	Saw blade location ring	117	M5x30 screw
88	Inner pressure board	118	Ø5 spring
89	M5x12 screw	119	Ø5 flat washer
90	Bearing housing	120	ST3.9x12screw

Parts List

No.	Description	No.	Description
121	Angular scale cover	150	Pointer
122	Angle board	151	M3 screw
123	Plastic washer	152	Fence lock block3
124	Handle M6x18	153	M6 plastic screw
125	Ø4 spring	154	Ø6 washer
126	Pointer of angle scale	155	M6x50 screw
127	Alloy	156	Auxiliary fence
128	Alloy washer	157	Sliding bar of fence
129	M5x10 screw	158	Fence
130	M6 screw	159	Ø5x40 pin
131	Ø 6 flat washer	160	Fence cover
132	Transparent guard	161	Spring1
133	M6x35 screw	162	Fence fasten block2
134	Riving knife	163	Spring3
135	Riving knife pressure board(1)	164	Control screw
136	Riving knife pressure board(2)	165	Triangle block
137	Clamp screw	166	Table insert
138	Ø 3x15 pin	167	Table insert washer1
139	Riving knife knob + cover	168	Table insert washer2
140	Lock handle	169	Extension bar cover
141	Ø5x11pin	170	M4x8 screw
142	Small connecting rod	171	M6x12 screw
143	Connecting rod1	172	Location block
144	Ø5x11 pin	173	M6 screw
145	Fence lock block1	174	Spout
146	Ø5x28 pin	175	Extension bar1
147	Ø5x30 pin	176	Extension table cover2
148	Fence fasten piece	177	Extension table2
149	Fence movable	178	Extension table cover1

Parts List

No.	Description	No.	Description
179	M6x15 screw	207	Fasten bar
180	Short pressure board	208	Ø20xØ15x1 washer
181	Side plate guard	209	Fasten wrench
182	M5x12 screw	210	M5x12 screw
183	Work table	211	Active plate
184	Extension table1	212	Rotation axis pressure board
185	Extension bar2	213	Torsional spring
186	Work table scale	214	Rotation axis
187	Extension bar1 cover	215	M5x8 screw
188	Strength board for body	216	Tension disc
189	M6x16 screw	217	Wrench
190	Long pressure board	218	Wrench
191	Weldment of extension board in work table	219	Wrench
192	Control bar3	220	Ø20 shaft jump ring
193	Extension fasten piece	221	ST4.8x20 screw
194	Ø6 inner jump ring	222	Roller pressure board
195	Spring2	223	Roller shaft
196	M8 screw(left)	224	Wheel
197	Hexagon control screw	236	M6x35 screw
198	M8screw	237	Plastic cover for fence in cross cut gauge(1)
199	Control bar1	238	Fence for cross cut gauge
200	Control bar2	239	Screw
201	Ø3x12 rivet	240	Plastic cover for fence in cross cut gauge(2)
202	Fasten block	241	T-adapter
203	Ø4.5x19 pin	242	Hose
204	Extension fasten block2		
205	Extension fasten block 1		
206	Ø12 shaft jump ring		

Parts Diagram

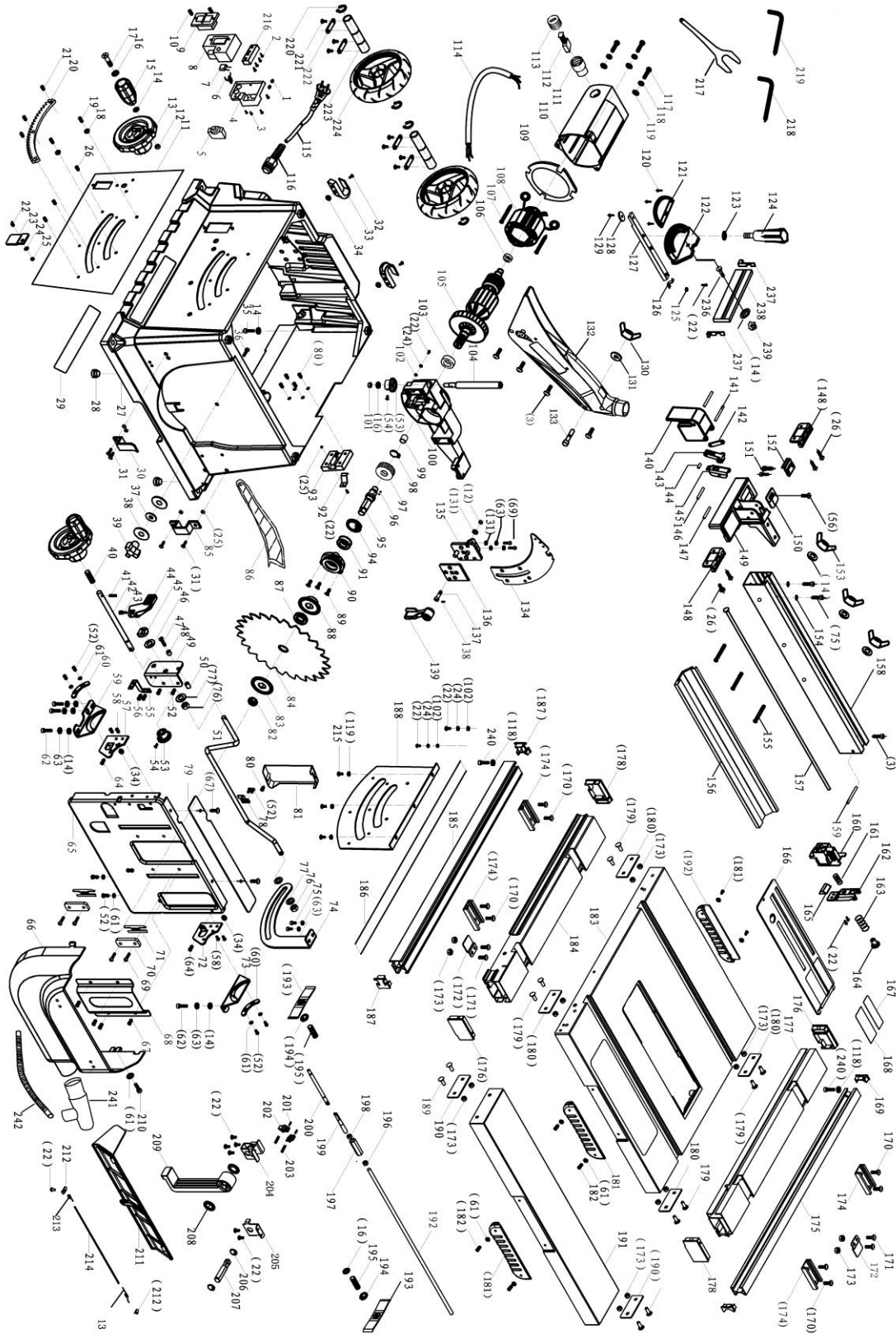

Parts List

No.	Description	No.	Description
01	Support	15	Pin II
02	M8×70 hex head bolt	16	Left support leg
03	Ø6 flat washer	17	Inner sleeve of support leg
04	Rollar shaft	18	Plastic support leg(second)
05	Wheel	19	Plastic support leg(first)
06	M8 locknut	20	Right support leg
07	M6 locknut	21	Support of roller 1
08	Washer	22	Support of roller 2
09	Lock piece	23	M6×8 inner hex screw
10	M6×45 outer hex bolt	24	Ø20 shaft jump ring
11	Locking cap	25	Ø20× ø32×1.5 flat washer
12	Cylinder pin 2.5×14	26	ST4.8×12 cross self-tapping screw
13	Locking knob	27	Hex boltm8×35
14	Locking knob's spring	28	ø8 flat washer

Parts Diagram

