



ORIGINAL INSTRUCTIONS

TABLE OF CONTENTS

Welcome to Lumberjack!

Dear customer, Congratulations on your purchase. Before using the Product for the first time please be sure to read these instructions for use. They provide you with all information necessary for using the product safely and to ensure its long service life.

Closely observe all safety information in these instructions!

General Power Tool Safety Warnings.....	01
Symbols & Cable Rating Chart	06
Machine Details and Product Features.....	07
Assembly.....	09
Operation.....	13
Working Advice.....	16
Maintenance and Service	17
Lumberjack Guarantee.....	20
Declaration of Conformity.....	22
Parts List.....	23
Parts Diagram.....	26

GENERAL POWER TOOL SAFETY WARNINGS

WARNING Read all safety warnings and all instructions. Failure to follow the warnings and instructions may result in electric shock, fire and/or serious injury.

Save all warnings and instructions for future reference. The term "power tool" in the warnings refers to your electric (corded) power tool or battery-operated (cordless) power tool.

1. Work area safety

a) Keep work area clean and well lit. Cluttered or dark areas invite accidents.

b) Do not operate power tools in explosive atmospheres, such as in the presence of flammable liquids, gases or dust. Power tools create sparks which may ignite the dust or fumes.

c) Keep children and bystanders away while operating a power tool. Distractions can cause you to lose control of the power tool.

2. Electrical safety

a) Power tool plugs must match the outlet. Never modify the plug in any way. Do not use any adapter plugs with grounded power tools. Unmodified plugs and matching outlets will reduce risk of electric shock.

b) Avoid body contact with grounded surfaces, such as pipes, radiators, ranges and refrigerators. There is an increased risk of electric shock if your body is grounded.

c) Do not expose power tools to rain or wet conditions. Water entering a power tool will increase the risk of electric shock.

d) Do not abuse the cord. Never use the cord for carrying, pulling or unplugging the power tool. Keep cord away from heat, oil, sharp edges or moving parts. Damaged or entangled cords increase the risk of electric shock.

e) When operating a power tool outdoors, use an extension cord suitable for outdoor use. Use of a cord suitable for outdoor use reduces the risk of electric shock.

f) If operating a power tool in a damp location is unavoidable, use a residual current device (RCD) protected supply. Use of an RCD reduces the risk of electric shock.

3. Personal safety

a) Stay alert, watch what you are doing and use common sense when operating a power tool. Do not use a power tool while you are tired or under the influence of drugs, alcohol or medication. A moment of inattention while operating power tools may result in serious personal injury.

b) Use personal protective equipment. Always wear eye protection. Protective equipment such as dust mask, non-skid safety shoes, hard hat, or hearing protection used for appropriate conditions will reduce personal injuries.

c) Prevent unintentional starting. Ensure the switch is in the off position before connecting to power source and/or battery pack, picking up or carrying the tool. Carrying power tools with your finger on the switch or energising power tools that have the switch on invites accidents.

d) Remove any adjusting key or wrench before turning the power tool on. A wrench or a key left attached to a rotating part of the power tool may result in personal injury.

GENERAL POWER TOOL SAFETY WARNINGS

e) Do not overreach. Keep proper footing and balance at all times. This enables better control of the power tool in unexpected situations.

f) Dress properly. Do not wear loose clothing or jewellery. Keep your hair, clothing and gloves away from moving parts. Loose clothes, jewellery or long hair can be caught in moving parts.

g) If devices are provided for the connection of dust extraction and collection facilities, ensure these are connected and properly used. Use of dust collection can reduce dust-related hazards.

4. Power tool use and care

a) Do not force the power tool. Use the correct power tool for your application. The correct power tool will do the job better and safer at the rate for which it was designed.

b) Do not use the power tool if the switch does not turn it on and off. Any power tool that cannot be controlled with the switch is dangerous and must be repaired.

c) Disconnect the plug from the power source and/or the battery pack from the power tool before making any adjustments, changing accessories, or storing power tools. Such preventive safety measures reduce the risk of starting the power tool accidentally.

d) Store idle power tools out of the reach of children and do not allow persons unfamiliar with the power tool or these instructions to operate the power tool. Power tools are dangerous in the hands of untrained users.

e) Maintain power tools. Check for misalignment or binding of moving parts, breakage of parts and any other condition that may affect the power tool's operation. If damaged, have the power tool repaired before use. Many accidents are caused by poorly maintained power tools.

f) Keep cutting tools sharp and clean. Properly maintained cutting tools with sharp cutting edges are less likely to bind and are easier to control.

g) Use the power tool, accessories and tool bits etc. in accordance with these instructions, taking into account the working conditions and the work to be performed. Use of the power tool for operations different from those intended could result in a hazardous situation.

5. Service

a) Have your power tool serviced by a qualified repair person using only identical replacement parts. This will ensure that the safety of the power tool is maintained.

b) If the replacement of the supply cord is necessary, this has to be done by the manufacturer or its agent in order to avoid a safety hazard.

6. Battery Tool Use and Care

a) Recharge only with the charger specified by the manufacturer. A charger that is suitable for one type of battery pack may create a risk of fire when used with another battery pack.

b) Use power tools only with specifically designated battery packs. Use of any other battery packs may create a risk of injury or fire.

GENERAL POWER TOOL SAFETY WARNINGS

c) When Battery pack is not in use, keep it away from other metal objects, like paper clips, coins, keys, nails, screws or other small metal object that can make a connection from one terminal to another. Shorting the battery terminals together may cause burns or a fire.

d) User abusive conditions, liquid may be ejected from the battery; Avoid contact. If contact accidentally occurs, flush with copious amounts of water. If liquid contacts eyes, seek medical help immediately. Liquid ejected from the batter may cause irritation or burns.

7 Additional Safety and Working Instructions

a) Dusts from materials such as lead-containing coatings, some wood types, minerals and metals can be harmful to one's health and cause allergic reactions, leading to respiratory infections and/or cancer. Materials containing asbestos may only be worked by specialists. Observe the relevant regulations in your country for the materials to be worked.

b) Prevent dust accumulation at the workplace. Dusts can easily ignite.

8 Safety Warnings for Chop and Mitre Saws

a) Never stand on the power tool. Serious injuries can occur when the power tool tips over or when inadvertently coming into contact with the saw blade.

b) Make sure that the guard operates properly and that it can move freely. Never lock the guard in place when opened.

c) Never remove cutting remainders, wood chips, etc. from the sawing area while the machine is running. Always guide the tool arm back to the neutral position first and then switch the machine off.

d) Guide the saw blade against the workpiece only when the machine is switched on. Otherwise there is damage of kickback, when the saw blade becomes wedged in the workpiece.

e) Keep handles dry, clean, and free from oil and grease. Greasy, oily handles are slippery causing loss of control.

f) Operate the power tool only when the work area to the workpiece is clear of any adjusting tools, wood chips, etc. Small pieces of wood or other objects that come in contact with the rotating saw blade can strike the operator with high speed.

g) Keep the floor free of wood chips and material remainders. You could slip or trip.

h) Always firmly clamp the piece to be worked. Do not saw workpieces that are too small to clamp. Otherwise, the clearance of your hand to the rotating saw blade is too small.

i) Use the machine only for cutting the materials listed under Intended Use. Otherwise, the machine can be subject to overload.

j) If the saw blade should become jammed, switch the machine off and hold the workpiece until the saw blade comes to a complete stop. To prevent kickback, the workpiece may not be moved until after the machine has come to a complete stop. Correct the cause for the jamming of the saw blade before restarting the machine.

k) Do not use dull, cracked, bent or damaged saw blades. Unsharpened or improperly set saw blades produce narrow kerf causing excessive friction, blade binding and kickback.

GENERAL POWER TOOL SAFETY WARNINGS

l) Always use saw blades with correct size and shape (diamond versus round) of bore. Saw blades that do not match the mounting hardware of the saw will run eccentrically, causing loss of control.

m) Do not use high speed steel (HSS) saw blades. Such saw blades can easily break.

n) Do not touch the saw blade after working before it has cooled. The saw blade becomes very hot while working.

o) Never operate the machine without the insert plate. Replace a defective insert plate. Without flawless insert plates, injuries are possible from the saw blade.

p) Check the cable regularly and have a damaged cable repaired only through an authorised customer service agent. Replace damaged extension cables. This will ensure that the safety of the power tool is maintained.

q) Store the machine in a safe manner when not being used. The storage location must be dry and lockable. This prevents the machine from storage damage, and from being operated by untrained persons.

r) Secure the workpiece. A workpiece clamped with clamping devices or in a vice is held more secure than by hand.

r) Never leave the machine before it has come to a complete stop. Cutting tools that are still running can cause injuries.

s) Never use the machine with a damaged cable. Do not touch the damaged cable and pull the mains plug when the cable is damaged while working. Damaged cables increase the risk of an electric shock.

9. Safety Warnings for Lasers

The mitre saw has a built-in laser light. The laser is CLASS IIIa. These lasers do not normally present an optical hazard. However, DO NOT stare at the beam, as this can cause flash blindness.

a) Do not remove or deface any product labels. Removing product labels increases the risk of exposure to laser radiation.

b) The laser beam can be harmful to the eyes. Always avoid direct eye exposure. Do not project the laser beam directly into the eyes of others or at any object other than the workpiece.

c) Do not look directly into the laser-beam-output aperture during operation.

d) Turn the laser on only when making cuts. The laser on the mitre saw is not a toy. Always keep it out of the reach of children. The laser light emitted from this device should never be directed toward any person for any reason.

e) Always turn the laser beam off when it is not in use. Leaving the tool on increases the risk of someone inadvertently staring into the laser's beam.

f) Be sure that the laser beam is aimed at a workpiece (such as wood or a rough-coated surface) that does not have a reflective surface.

g) Do not use on materials that have shiny, reflective surfaces, such as sheet metal. The reflective surface could reflect the beam back at the operator. Be aware that laser light reflected off of a mirror or any other reflective surfaces can also be dangerous.

h) Always wear laser-protective eyewear when working on or near reflective surfaces.

9.8 Do not attempt to activate the laser when the tool housing is removed.

i) The laser is activated by means of a button switch that is independent of the main switch for the saw.

GENERAL POWER TOOL SAFETY WARNINGS

j) Do not replace the laser light assembly with a different one. Any repairs must be carried out by the laser manufacturer or an authorized service agent.

k) Do not attempt to repair the laser guide by yourself.

l) Do not attempt to change any parts of the laser guide.

9. Using an Extension Cable.

a) If an extension cable is required, use an approved triple core extension cable suitable for the power input of the tool.

b) Grounded tools always require a three wire extension cable.

c) As the distance from the supply outlet increases you must use a heavier gauge extension cable. Using extension cables with inadequately sized wire causes a serious drop in voltage, resulting in loss of power and possible tool damage.

d) The smaller the gauge number of the wire the greater the capacity of the cord.

e) When using a cable reel, always unwind the cable completely.

SYMBOLS AND POWER RATING CHART



Danger! – Read the operating instructions to reduce the risk of injury.



Caution! Wear safety goggles.



Caution! Wear ear defenders. The impact of noise can cause damage to hearing.



Caution! Risk of Injury! Do not reach into the running saw blade.



Caution! Wear a dust mask.



Caution: Laser radiation. Do not look into the beam! Laser class II product!

Amperes	7.5M	15M	25M	30M	45M	60M
0 – 2.0	6	6	6	6	6	6
2.1 – 3.4	6	6	6	6	6	6
3.5 - 5.0	6	6	6	6	10	15
5.1 – 7.1	10	10	10	10	15	15
7.1 – 12.0	15	15	15	15	20	20
12.1 – 20.0	20	20	20	20	25	-

MACHINE DETAILS AND PRODUCT FEATURES

Machine Details

Specifications:

Mains Voltage -	230V
Power Consumption -	2000W
No load Speed -	5000rpm
Blade Spec -	254x30x24T
Cutting Capacity:	
At 0° / 0°-	315x90mm
At -45° / 0°-	215x90mm
At 0° / -45°-	315x40mm
At 0° / +45° -	315x40mm
At -45° / -45°-	215x40mm
At +45° / +45°-	215x40mm
Gross Weight -	20.5kg
Nett Weight -	17.0kg

Package Contents:

254mm Mitre saw
Dust Bag
Fast clamp
Blade wrench
Dust bag

Intended Use

The power tool is intended as a stationary machine for making straight lengthways and crossways cuts in wood. In this, mitre angles from -45° to $+45^{\circ}$ as well as bevel angles from 0 to 45° are possible.

The capacity of the power tool is designed for sawing hardwood and softwood.

The power tool is not suitable for cutting aluminium or other non-ferrous metals or alloys.

Product Features

1. Switch handle
2. On/Off Trigger switch
3. Upper blade guard
4. Lower blade guard
5. Base
6. Table insert
7. Mitre handle
8. Mitre stop locking lever
9. Positive mitre stop
10. Mounting hole
11. Handhold for transportation
12. Extension wing
13. Fast clamp
14. Upper fence
15. Lower fence
16. 0° stop pin
17. Dust bag
18. Blade
19. Motor
20. Spindle lock
21. Lock-down pin
22. Slide carriage lock knob
23. Bevel lock knob
24. Bevel scale
25. Table
26. Mitre scale
27. Hex wrench
28. Laser

MACHINE DETAILS AND PRODUCT FEATURES

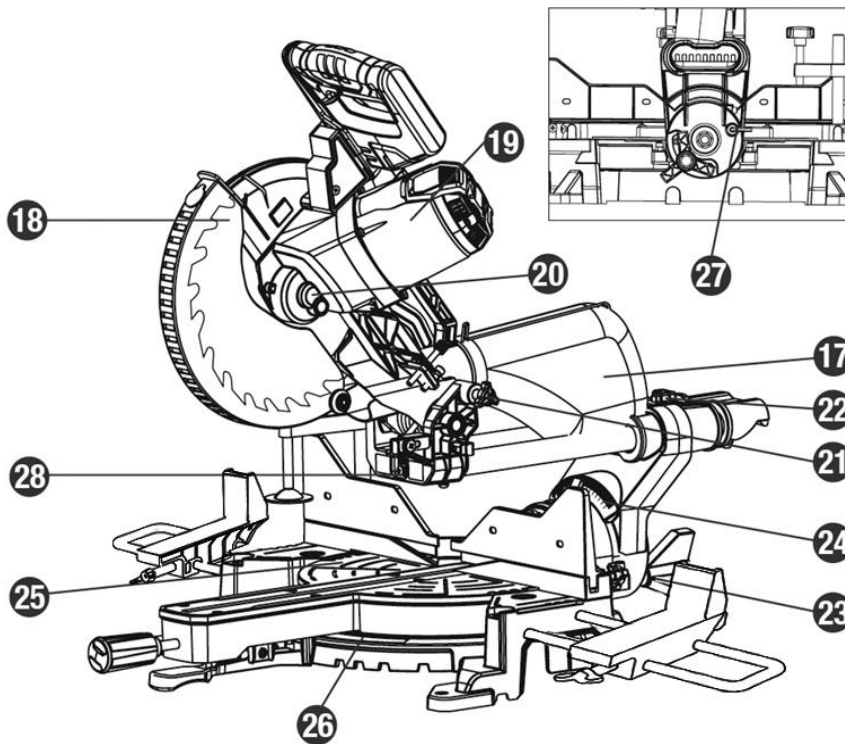
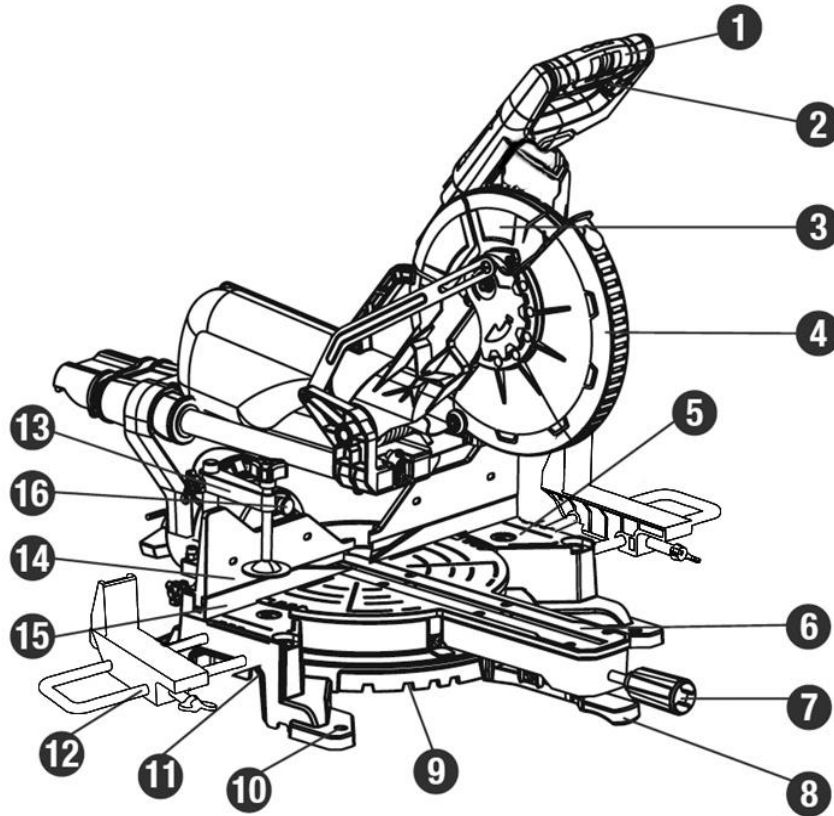

ASSEMBLY INSTRUCTIONS

Assembly

Avoid unintentional starting of the machine. During assembly and for all work on the machine, the power plug must not be connected to the mains supply.

Carefully remove all parts included in the delivery from their packaging.

Remove all packaging material from the machine and the accessories provided.

Before starting the operation of the machine for the first time, check if all parts listed in the box content section have been supplied

Note: Check the power tool for possible damage. Before further use of the machine, check that all protective devices are fully functional. Any lightly damaged parts must be carefully checked to ensure flawless operation of the tool. All parts must be properly mounted and all conditions fulfilled that ensure faultless operation.

Damaged protective devices and parts must be immediately replaced by an authorised service centre.

Always tighten the locking knob (7)&(23) firmly before sawing. Otherwise the saw blade can become wedged in the workpiece.

Stationary or Flexible Mounting

To ensure safe handling, the machine must be mounted on a level and stable surface (e. g., workbench) prior to using.

Mounting to a Working Surface

– Fasten the power tool with suitable screw fasteners to the working surface. The mounting holes (10) serve for this purpose.

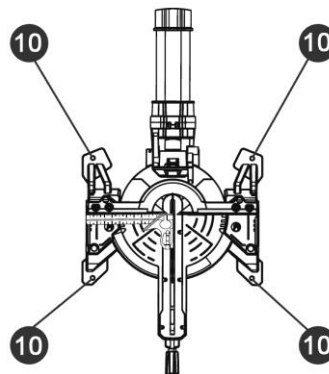

or

– Clamp the power tool with commercially available screw clamps by the feet to the working surface.

Mounting to a Saw Stand

Any universal saw stand which will accept mounting holes 450mm wide by 340mm in length will suffice.

Read all safety warnings and instructions included with the worktable. Failure of observing safety warnings and instructions can lead to electrical shock, fire and/or cause serious injuries.

Assemble the worktable properly before mounting the power tool. Perfect assembly is important in order to prevent the risk of collapsing.

– Mount the power tool in transport position on the saw stand.

ASSEMBLY INSTRUCTIONS

Dust/Chip Extraction

Dusts from materials such as lead-containing coatings, some wood types, minerals and metal can be harmful to one's health. Touching or breathing-in the dusts can cause allergic reactions and/or lead to respiratory infections of the user or bystanders.

Certain dusts, such as oak or beech dust, are considered as carcinogenic, especially in connection with wood-treatment additives (chromate, wood preservative). Materials containing asbestos may only be worked by specialists.

– Always use dust extraction or the Dust bag (17) provided

– Provide for good ventilation of the working place.

– It is recommended to wear a P2 filter-class respirator.

Observe the relevant regulations in your country for the materials to be worked.

The dust/chip extraction can be blocked by dust, chips or workpiece fragments.

– Switch the machine off and pull the mains plug from the socket outlet.

– Wait until the saw blade has come to a complete stop.

– Determine the cause of the blockage and correct it.

Integrated Dust Extraction.

– Insert the dust bag firmly onto the machine

During sawing, the dust bag must never come in contact with moving tool components.

Always empty the dust bag in good time.

External Dust Extraction

For dust extraction, you can also connect the extraction port (25) to a vacuum hose (internal Ø 40 mm).

The dust extractor must be suitable for the material being worked. When vacuuming dry dust that is especially detrimental to health or carcinogenic, use a special dust extractor.

Changing the Blade

Before any work on the machine itself, pull the mains plug.

When mounting the saw blade, wear protective gloves. Danger of injury when touching the saw blade.

Use only saw blades whose maximum permitted speed is higher than the no-load speed of the power tool.

Use only saw blades that correspond with the characteristic data given in these operation instructions.

Use only saw blades recommended by the tool manufacturer, and suitable for sawing the materials to be cut.

ASSEMBLY INSTRUCTIONS

Removing blade

- Unplug the tool from the power source.
- Adjust the lock-down pin to raise the cutting head.
- Loosen the cover plate screw (1) about 2 turns with a Phillips screwdriver. Do not remove this screw from the tool.

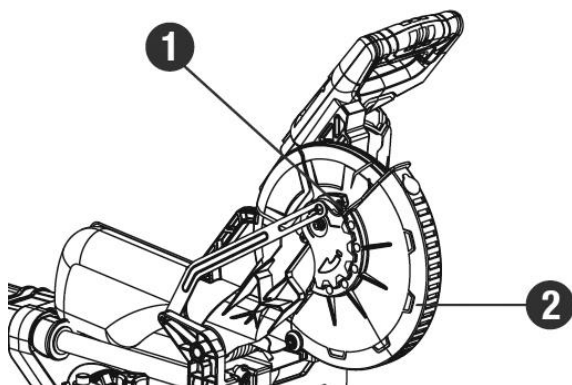

- Lift and hold up the lower blade guard (2) to expose the threaded blade bolt (3).

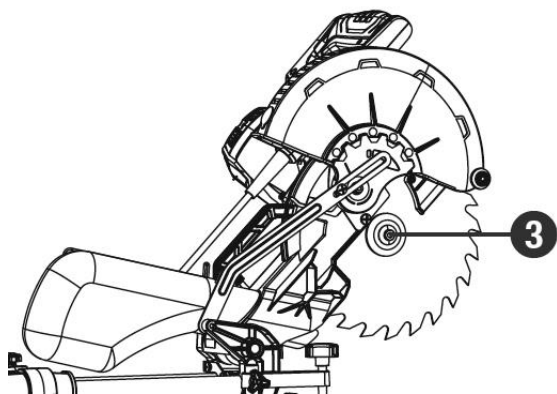

- Press and hold the spindle-lock button (4) and rotate the blade at the same time, until it is locked in position.

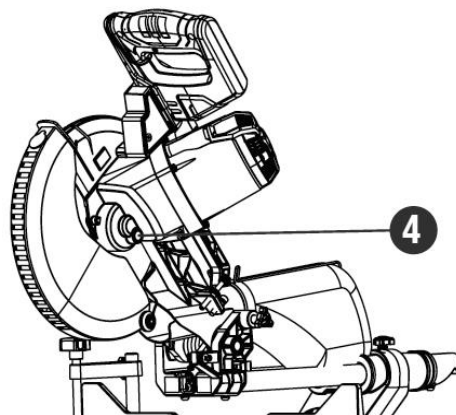

- Continue to hold the spindle lock button to keep it engaged, while using the wrench to turn the threaded blade bolt clockwise and remove the threaded blade bolt.
- Remove the outer flange (5) and the blade (6). Wipe the flanges and spindle to remove any dust and debris.

Installing blade

Unplug the mitre saw before changing/installing the blade.

- Install a 10" (25.4 cm) blade with 5/8" (15.9 mm) arbor onto the arbor shaft (7). Match the arrow on the blade with the arrow on the upper blade guard. Make sure that the blade teeth are pointing downward.
- Place the out flange against the blade and on the arbor. Thread the blade bolt onto the arbor in an anti-clockwise direction.
- Place the blade hex wrench into the blade bolt.

ASSEMBLY INSTRUCTIONS

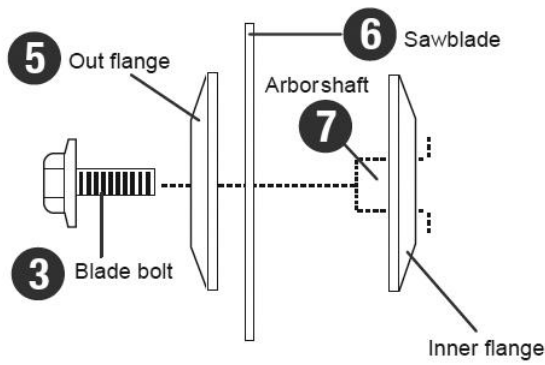

- Press the spindle lock button, holding it in firmly while turning the blade anti-clockwise. When spindle lock engages, continue to press it in while tightening the blade bolt securely.
- Rotate the lower blade guard back to its original position until the slot in the cover plate engages with the cover plate screw. While holding the lower blade guard, tighten the screw with a Phillips screwdriver.
- Verify that the operation of the guard does not bind or stick.
- Be sure the spindle lock is released

OPERATION

Operation

Before any work on the machine itself, remove the mains plug from outlet.

Transport Safety

The lock down pin (21) enables easier handling of the machine when transporting to various working locations.

Releasing the Machine (Working Position)

- Push the tool arm by the handle (1) down a little in order to relieve the lock down pin (21).
- Pull the lock down pin (21) completely outward and turn 90°, and loose.
- Guide the tool arm slowly upward.

Securing the Machine (Transport Position)

- Swing the tool arm by handle (1) toward the saw table (5) until it reaches the saw table. Turn lock down pin (21) 90° and push in to secure.

The tool arm is now securely locked for transport. Please note, if there is any cutting depth setting, the lock pin may not work. Release the cutting depth limitation, and then lock the cutting head in.

Setting the Maximum Cutting Depth

The maximum depth travel of the cutting head was set at the factory. Check to see that the blade does not extend more than 11/16" (1.7 cm) below the table insert, and does not touch the control arm throat or any part of the base or table.

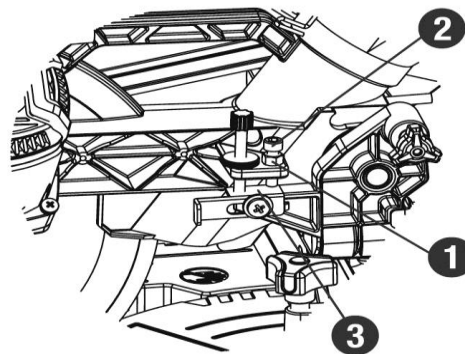

- Loosen the lock nut (1) to free the depth screw (2).

- Move the cutting head down until the blade extends just 11/16" (1.7 cm) below the table insert.

- Adjust the depth screw to touch the stop plate (3), and then tighten the lock nut to secure the depth screw.

- Recheck the blade depth by moving the cutting head front to back through the full motion of a cut along the control arm. If the blade touches the inside of the control arm, readjust the setting.

- When it is properly set, tighten the lock nut to lock the depth screw.

Setting the Trenching Facility

In its normally set position the trenching facility permits the blade to cut completely through the workpiece, but when set the trenching facility allows the blade to cut only part way through the workpiece.

- Slide the stop plate (1) towards the front position.

- Loosen the lock nut (2) to free the lock knob (3), turn the stop knob until the cutting head down until the teeth of the blade are at the desired depth.

OPERATION

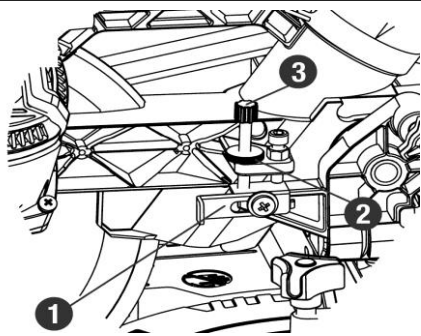

- While holding the upper arm in that position, tighten the lock nut to secure the stop knob.
- Recheck the blade depth by moving the cutting head front to back through the full motion of typical cut along the control arm.

Setting the Mitre Angle

- When a mitre cut is required, unlock the table by turning the mitre handle (1) anti-clockwise.

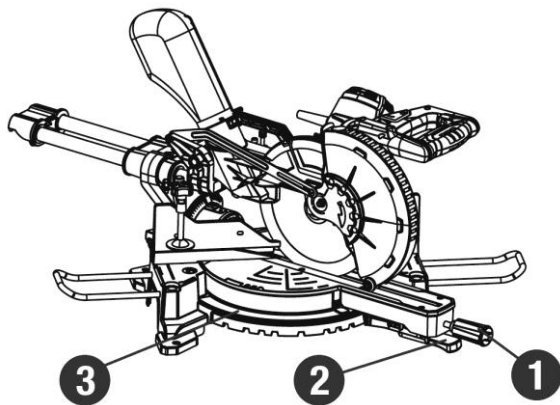

- While holding the mitre handle, lift up on the positive stop locking lever (2).
- Rotate the table to the right or left with the mitre handle.
- When the table is in the desired position, as shown on the mitre scale (3), release the positive stop locking lever and tighten the mitre handle. The table is now locked at the desired angle. Positive stops are provided at 0°, 15°, 22.5°, 31.6° and 45°.

Setting the Bevel Angle

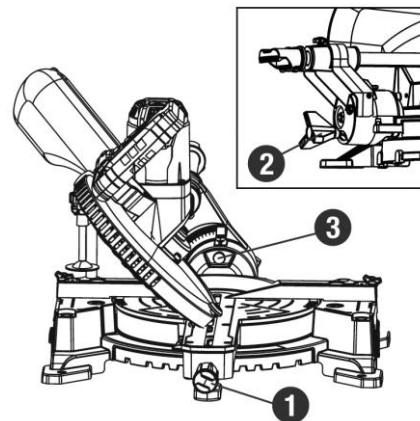

Make sure that the table is at 0° and lock the mitre lock handle (1). Adjust the lock-down pin to release the cutting head.

- Loosen the bevel lock knob (2) by turning it clockwise and adjust the cutting head to get the desired angle. Please note that when bevelling the cutting head to the right, you should first pull out the 0° stop pin (3), otherwise the cutting head won't be bevelled to the right. The blade can be positioned at any angle, from a 90° straight cut (0° on the scale) to a 45° left / right bevel.

Clamping the Workpiece

To ensure optimum working safety, the workpiece must always be firmly clamped.

Do not saw workpieces that are too small to clamp.

While clamping the workpiece, do not reach under the clamping lever of either clamps with your fingers.

- Press the workpiece firmly against the fence (14).
- Insert the fast clamp (13) into one of the holes intended for this purpose.

OPERATION

- Adapt the fast clamp to the workpiece by turning the threaded rod.
- Tighten the main screw in order to clamp the workpiece.

Adjusting the Cutting Angle

To ensure precise cuts, the basic adjustment of the machine must be checked and adjusted as necessary after intensive use.

Always tighten the locking knob (7) & (23) firmly before sawing.

Otherwise the saw blade can become wedged in the work piece.

Switching On

- To **start** the machine, press the On/Off switch (2) ① then press lever ② at the same time and keep it pressed.

Note: For safety reasons, the On/Off switch (3) cannot be locked; it must remain pressed during the entire operation.

- For **sawing**, you must additionally press lever ① in addition to actuating the On/Off switch ②.

Switching Off

- To **switch off** the machine, release the On/Off switch (2).

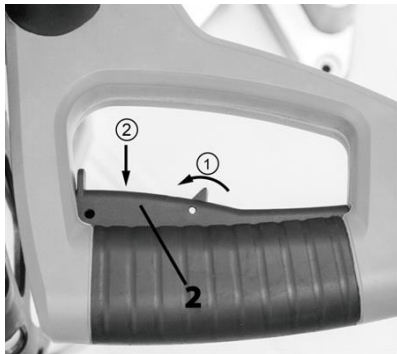

Cross Cutting

When cutting, it is not always necessary to use the sliding carriage. In this case make sure that the sliding carriage lock (22) is tightened to prevent the saw arm from sliding.

- With the machine in working position, and the bevel and mitre angle set to desired angles and the workpiece clamped, loosen the sliding carriage lock (22), pull handle (1) towards you.
- Press the On/off switch (2). Pull down on handle (1) and push the blade down through the workpiece then away from your body.
- Once the cut is complete raise the head and release the on/off switch (2).
- Wait until the blade has stopped spinning before removing the workpiece

WORKING ADVICE

Working Advice

General Sawing Instructions

For all cuts, it must first be ensured that the saw blade at no time can come in contact with the fence, screw clamps or other machine parts. Remove possibly mounted auxiliary stops or adjust them accordingly.

Protect the saw blade against impact and shock.
Do not subject the saw blade to lateral pressure.

Do not saw warped/bent workpieces. The workpiece must always have a straight edge to face against the fence.

Long workpieces must be under laid or supported at their free end.

Position of the Operator

Do not stand in a line with the saw blade in front of the machine. Always stand aside of the saw blade. This protects your body against possible kickback.

– Keep hands, fingers and arms away from the rotating saw blade.

– Do not cross your arms when operating the tool arm.

Transport

Before transporting the power tool, the following steps must be carried out:

- Bring the machine into the transport position.
- Remove all accessories that cannot be mounted firmly to the power tool.

If possible, place unused saw blades in an enclosed container for transport.

- Carry the machine by the base or the carry handle only.

The power tool should always be carried by two persons in order to avoid back injuries.

When transporting the power tool, use only the transport devices and never use the protective devices.

Maintenance and Service

Maintenance and Service

Maintenance and Cleaning

Adjustments

Mitre Angle Pointer Adjustment

- Move the table to the 0° positive stop.

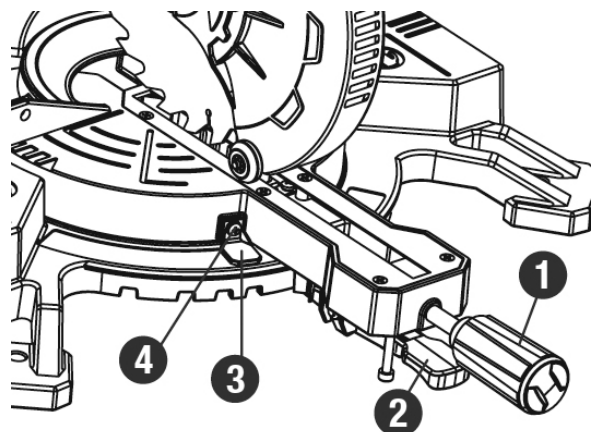

- Loosen the screw (4) that holds the indicator with a Phillips screwdriver.
- Adjust the indicator (3) to the 0° mark and retighten the screw.

Adjusting the Fence

- Lower the cutting head and lock in position.

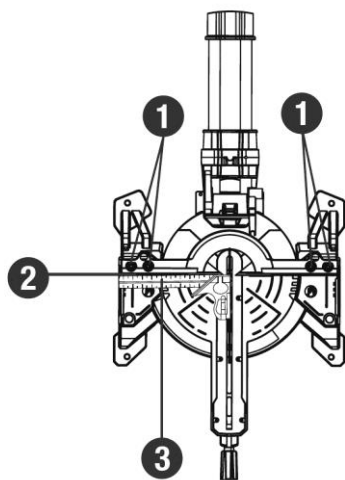

- Remove the fixing screws and then pull out the left and right upper sliding fences (2). Four fence locking bolts (1) will appear.

- Lower the cutting head and lock it in position.

- Using a square (3) lay the heel of the square against the blade and the ruler against the fence (2) as shown.

- Loosen the four fence locking bolts with a 4 mm hex wrench.

- Adjust the fence 90° to the blade and then tighten the four fence locking bolts.

- After fence has been aligned, make a cut at 90° using a scrap piece of wood and check squareness on the piece. Readjust if necessary.

90° (0°) Bevel Adjustment

- Loosen bevel lock knob (1) and push the 0° stop pin (2) in. Tilt the cutting arm completely to the right. Tighten the bevel lock knob.

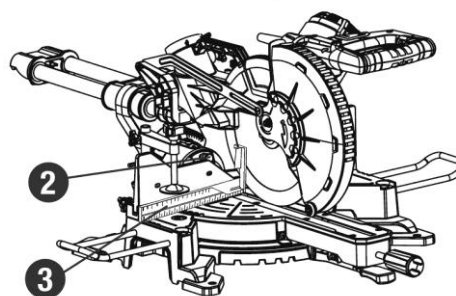
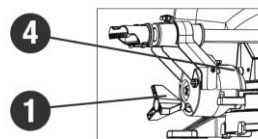

- Place a combination square (3) on the table with the ruler against the table and the heel of the square against the saw blade.

Maintenance and Service

– If the blade is not 90° square with the table, loosen the bevel lock knob, put a 4mm hex wrench into the hole (4) located in the left side end of the arm holder, turn the hex screw clockwise or anti-clockwise to make the blade square to the table.

– Tighten bevel lock knob when alignment is achieved.

90° Bevel Pointer Adjustment

When the blade is exactly 90° to the table, loosen the bevel indicator screw (1) using a Phillips screwdriver.

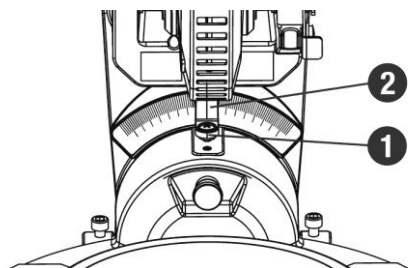

– Adjust bevel indicator (2) to the “0” mark on the bevel scale and retighten the screw.

45° Bevel Adjustment Left and Right

– Loosen the bevel lock knob (1) and tilt the cutting head completely to the left.

– Pull out the 0° stop pin (2).

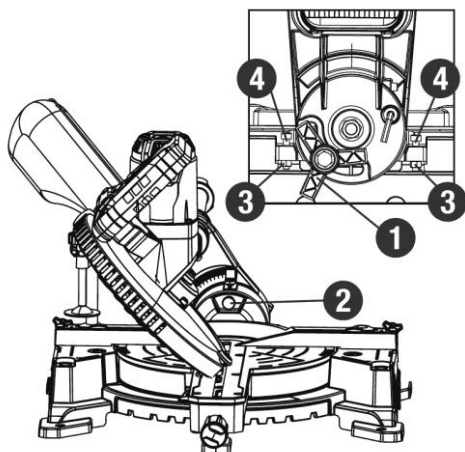

– Loosen the bevel lock knob and tilt the cutting head completely to the left. The mitre angle scale must be at 0°.

– Using a combination square, check to see if the blade is at a 45° angle to the table.

– If the blade is not at 45° to the table, tilt the cutting arm to the right, loosen the lock nut (3) on the bevel angle adjustment bolt (4) and use a 5 mm hex wrench to adjust bolt depth in or out to increase or decrease the bevel angle.

– Tilt the cutting arm to the left to 45° bevel and recheck for alignment.

– Repeat above steps until the blade is at 45° to the table.

– Tighten bevel lock knob and lock nut when alignment is achieved.

– The right bevel 45° adjustment uses the same sequence as the left bevel adjustment, just adjusting the adjustment bolt to 45° on the right.

Replacing the Carbon Brushes

Replace both carbon brushes when either has less than 1/4” (0.6 cm) length of carbon remaining, or if the spring or wire is damaged or burned. To inspect or replace brushes, first unplug the saw. Remove the two screws on the back cover of the motor and take the cover off. Move the coil spring which press on the carbon brush to other side to free the carbon brush. Pull out the brush and the wire which connect to the holder. Replace it for a new carbon brush. When replace for the other side. To reassemble, reverse the procedure. Tighten two screws on the back cover.

Maintenance and Service

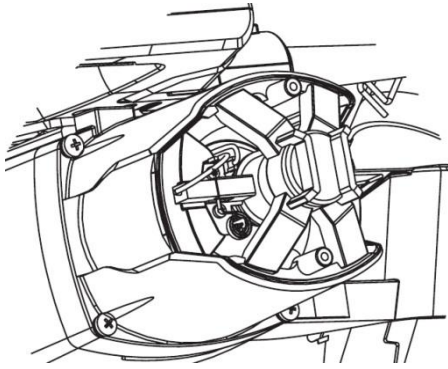

This will avoid a break-in period that reduces motor performance and increases wear.

Lubrication

All the motor bearings in this tool are lubricated with a sufficient amount of high-grade lubricant for the life of the unit under normal operating conditions; therefore, no further lubrication is required.

Lubricate the following as necessary:

Chop pivot: Apply light machine oil to points indicated in illustration.

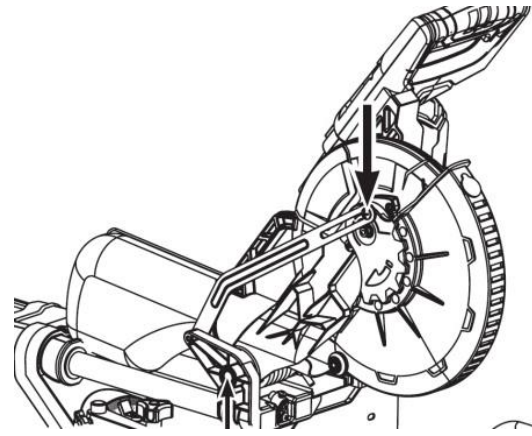

Central pivot of plastic guard: Use light household oil (sewing machine oil) on metal-to-metal or metal-to-plastic guard contact areas as required for smooth, quiet operation. Avoid excessive oil as sawdust will cling to it.

Cleaning

For safe and proper working, always keep the power tool and its ventilation slots clean.

The retracting blade guard must always be able to move freely and retract automatically. Therefore, always keep the area around the retracting blade guard clean.

Remove dust and chips after each working procedure by blowing out with compressed air or with a brush

LUMBERJACK GUARANTEE

1. Guarantee

1.1 Lumberjack guarantees that for a period of 12 months from the date of purchase the components of qualifying products (see clauses 1.2.1 to 1.2.8) will be free from defects caused by faulty construction or manufacture.

1.2. During this period Lumberjack, will repair or replace free of charge any parts which are proved to be faulty in accordance with paragraph 1.1 providing that:

1.2.1 You follow the claims procedure set out in clause 2

1.2.2 Lumberjack and its authorised dealers are given reasonable opportunity after receiving notice of the claim to examine the product

1.2.3 If asked to do so by Lumberjack or its Authorised dealer, you return the product at your own cost to Lumberjack's or supplying Authorised Dealer's premises, for the examination to take place clearly stating the Returns Material Authorisation number given by Lumberjack or an Authorised Dealer.

1.2.4 The fault in question is not caused by industrial use, accidental damage, fair wear and tear, wilful damage, neglect, incorrect electrical connection, misuse, or alteration or repair of the product without approval.

1.2.5 The product has been used in a domestic environment only

1.2.6 The fault does not relate to consumable items such as blades, bearings, drive belts, or other wearing parts which can reasonably be expected to wear at different rates depending on usage.

1.2.7 The product has not been used for hire purposes.

1.2.8 The product has been purchased by you as the guarantee is not transferable from a private sale.

2. Claims Procedure

2.1 In the first instance please contact the Authorised Dealer who supplied the product to you. In our experience many initial problems with machines that are thought to be faulty due to faulty parts are actually solved by correct setting up or adjustment of the machine. A good Authorised Dealer should be able to resolve the majority of these issues much more quickly than processing a claim under the guarantee. If a return is requested by the Authorised Dealer or Lumberjack, you will be provided with a Returns Material Authorisation number which must be clearly stated on the returned package, and any accompanying correspondence. Failure to provide a Returns Material Authorisation number may result in item being refused delivery at Authorised Dealer.

2.2 Any issues with the product resulting in a potential claim under the guarantee must be reported to the Authorised Dealer from which it was purchased within 48 hours of Receipt.

2.3 If the Authorised Dealer who supplied the product to you has been unable to satisfy your query, any claims made under this Guarantee should be made directly to Lumberjack. The Claim itself should be made in a letter setting out the date and place of purchase, giving a brief explanation of the problem which has led to the claim. This letter should be then sent with proof

LUMBERJACK GUARANTEE

of purchase to Lumberjack. If you include a contact number with this it will speed your claim up.

2.4 Please note that it is essential that the letter of claim reaches Lumberjack on the last day of this Guarantee at the latest. Late claims will not be considered.

3. Limitation of Liability

3.1 We only supply products for domestic and private use. You agree not to use the product for any commercial, business or resale purposes and we have no liability to you for any loss of profit, loss of business, business interruption or loss of business opportunity.

3.2 This Guarantee does not confer any rights other than these expressly set out above and does not cover any claims for consequential loss or damage. This Guarantee is offered as an extra benefit and does not affect your statutory rights as a consumer.

4. Notice

This Guarantee applies to all product purchased from an Authorised Dealer of Lumberjack within the United Kingdom. Terms of Guarantee may vary in other countries.

CE DECLARATION OF CONFORMITY

TOOLSAVE

Unit C, Manders Ind. Est.,
Old Heath Road, Wolverhampton,
WV1 2RP.

Tel: 01902 450 470

Declares that the MITRE SAW(SCMS254DB)

Is in compliance with the regulations included in the Directives:2006/42/EC

EC DECLARATION OF CONFORMITY

Certificate for EC-type examination delivered by Intertek Testing Services Shanghai Building
No.86,1198 Qinzhou Road(North),Shanghai 200233, China (Report No.:190102430SHA-V1)

Person who declares: Bill Evans



01.03.2020

The Director

A handwritten signature in black ink, appearing to read 'Bill Evans', written over a faint, illegible stamp or background.

Parts List

No.	Description	No.	Description
1	Screw	28	Stator
2	Screw	29	End Cap
3	Washer	30	Spring Washer
4	Laser Switch	31	Tapping Screw
5	Tapping Screw	32	Motor Housing
6	Upper Handle	33	Brush Holder
7	Cord Press Plate	34	Carbon Brush
8	Terminal	35	Rating Label
9	Switch Spring	36	Carbon Brush Spring
10	Switch	37	Warning Label
11	Inner Wire Sleeve	38	Pivot Shaft
12	Switch Trigger Assembly	39	Spring Sleeve
12-1	Switch Trigger	40	Big Torsion Spring
12-2	Switch Trigger Key	41	Screw
12-3	Spring	42	Cord Clip
12-4	Pin	43	Nut
13	Transformer	44	Knurled Nut
14	Cable Sheath	45	Half Rod Screws
15	Lower Handle	46	Depth Adjuster
16	Power Cord And Plug	47	Lock Pin Cover
17	Nut	48	Lock Pin
18	Connection Support	49	Spring
19	Screw	50	Circlip
20	Side Cover	51	Dust Chimney
21	Screw	52	Fix Guard
22	Bearing	53	Bearing
23	Fan Baffle	54	Brand Label
24	Armature	55	Shaft Circlip
25	Bearing	56	Big Gear
26	Bearing Sleeve	57	Flat Key
27	Tapping Screw	58	Spindle

Parts List

No.	Description	No.	Description
59	Gear Box Cover	87	Washer
60	Inner Flange	88	Hex Screw
61	Blade	89	Location Pin Sleeve
62	Outer Flange	90	Hex Screw
63	Hex Screws	91	Screw
64	Hex Screws	92	Shoulder Screw
65	Moving Guard Support	93	Linkage
66	Torsional Spring	94	Wave Washer
67	Shoulder Screws	95	Bevel Indicator
68	Screws	96	Laser Holder
69	Lower Blade Guard Assembly	97	Laser
69-1	Moving Guard	98	Angle Location Pin
69-2	Cast Centre	99	Inner Hex Screw
69-3	Rivet	100	Spring Washer
70	Laser Warning Label	101	Shoulder Screws
71	Table Insert	102	Washer
72	Washer	103	Cutting Depth Stop Plate
73	Locknut	104	O-Ring
74	Inner Tooth Washer	105	Location Pin Sleeve
75	Moving Guard Wheel	106	Rotary Shaft
76	Knob	107	Bevel Scale
77	Knob	108	Bracket
78	Clamp Arm	109	Location Pin
79	Clamp	110	Drive Plate
80	Washer	111	Screw
81	Spring Washer	112	Bearing Cover
82	Screw	113	Rubber Ring
83	Support Pole	114	Knob
84	Mitre Indicator	115	Spring
85	Turntable	116	Linear Bearing
86	Nut Clamping Piece	117	Hex Key Store

Parts List

No.	Description	No.	Description
118	Screw	143	Mitre Handle
119	Hex Key	144	Extension Bar
120	Hex Bolt	145	Handle Cap
121	Bevel Locker	146	Miter Scale
122	Locknut	147	Base
123	Washer	148	Locknut
124	Washer	149	Dust Bag
125	Slide End Cap	150	Spring Sleeve Ring
126	Slide End Cap Cover	151	Arm
127	Guide Bar	152	Screw
128	Left Slide Fence	153	Hex Screw
129	Right Slide Fence	154	Hex Screw
130	Knob	155	Cross Head Screws
131	Screw	156	Left Extension Table
132	Screw	157	Front Table Foot
133	Fence	158	Cross Head Screws
134	Spring Washer	159	Screws
135	Lock Plate	160	Self-Tapping Screws
136	Square Nut	161	End Stop Plate
137	Screw	162	Dust Port
138	Spring	163	Right Extension Table
139	Location Push Button	164	Spring
140	Mitre Angle Lock Rod	165	Wing Nut
141	Spring	166	Cross Head Screws
142	Front Table Support Foot	167	Lock Nut

Parts Diagram

