



SAFETY AND OPERATING MANUAL BENCH TOP ROUTER TABLE WITH INTEGRATED ROUTER RT1500



ORIGINAL INSTRUCTIONS

Version 2019.1.23



RT1500

TABLE OF CONTENTS

Welcome to Lumberjack!

Dear customer, Congratulations on your purchase. Before using the Product for the first time please be sure to read these instructions for use. They provide you with all information necessary for using the product safely and to ensure its long service life.

Closely observe all safety information in these instructions!

General Power Tool Safety Warnings.....	01
Symbols & Cable Rating Chart	05
Machine Details and Product features.....	06
Assembly.....	07
Operation.....	10
Maintenance and Service.....	12
Lumberjack Guarantee.....	13
Declaration of conformity.....	15
Parts list.....	16
Parts Diagram.....	21



RT1500

GENERAL POWER TOOL SAFETY WARNINGS

WARNING Read all safety warnings and all instructions. Failure to follow the warnings and instructions may result in electric shock, fire and/or serious injury.

Save all warnings and instructions for future reference. The term "power tool" in the warnings refers to your electric (corded) power tool or battery-operated (cordless) power tool.

1. Work area safety

a) Keep work area clean and well lit. Cluttered or dark areas invite accidents.

b) Do not operate power tools in explosive atmospheres, such as in the presence of flammable liquids, gases or dust. Power tools create sparks which may ignite the dust or fumes.

c) Keep children and bystanders away while operating a power tool. Distractions can cause you to lose control.

2. Electrical safety

a) Power tool plugs must match the outlet. Never modify the plug in any way. Do not use any adapter plugs with grounded power tools. Unmodified plugs and matching outlets will reduce risk of electric shock.

b) Avoid body contact with grounded surfaces, such as pipes, radiators, ranges and refrigerators. There is an increased risk of electric shock if your body is grounded.

c) Do not expose power tools to rain or wet conditions. Water entering a power tool will increase the risk of electric shock.

d) Do not abuse the cord. Never use the cord for carrying, pulling or unplugging the power tool. Keep cord away from heat, oil, sharp edges or moving parts. Damaged or entangled cords increase the risk of electric shock.

e) When operating a power tool outdoors, use an extension cord suitable for outdoor use. Use of a cord suitable for outdoor use reduces the risk of electric shock.

f) If operating a power tool in a damp location is unavoidable, use a residual current device (RCD) protected supply. Use of an RCD reduces the risk of electric shock.

3. Personal safety

a) Stay alert, watch what you are doing and use common sense when operating a power tool. Do not use a power tool while you are tired or under the influence of drugs, alcohol or medication. A moment of inattention while operating power tools may result in serious personal injury.

b) Use personal protective equipment. Always wear eye protection. Protective equipment such as dust mask, non-skid safety shoes, hard hat, or hearing protection used for appropriate conditions will reduce personal injuries.

c) Prevent unintentional starting. Ensure the switch is in the off position before connecting to power source and/or battery pack, picking up or carrying the tool. Carrying power tools with your finger on the switch or energising power tools that have the switch on invites accidents.

d) Remove any adjusting key or wrench before turning the power tool on. A wrench or a key left attached to a rotating part of the power tool may result in personal injury.



GENERAL POWER TOOL SAFETY WARNINGS

e) Do not overreach. Keep proper footing and balance at all times. This enables better control of the power tool in unexpected situations.

f) Dress properly. Do not wear loose clothing or jewellery. Keep your hair, clothing and gloves away from moving parts. Loose clothes, jewellery or long hair can be caught in moving parts.

g) If devices are provided for the connection of dust extraction and collection facilities, ensure these are connected and properly used. Use of dust collection can reduce dust-related hazards.

4. Power tool use and care

a) Do not force the power tool. Use the correct power tool for your application. The correct power tool will do the job better and safer at the rate for which it was designed.

b) Do not use the power tool if the switch does not turn it on and off. Any power tool that cannot be controlled with the switch is dangerous and must be repaired.

c) Disconnect the plug from the power source and/or the battery pack from the power tool before making any adjustments, changing accessories, or storing power tools. Such preventive safety measures reduce the risk of starting the power tool accidentally.

d) Store idle power tools out of the reach of children and do not allow persons unfamiliar with the power tool or these instructions to operate the power tool. Power tools are dangerous in the hands of untrained users.

e) Maintain power tools. Check for misalignment or binding of moving parts, breakage of parts and any other condition that may affect the power tool's operation. If damaged, have the power tool repaired before use. Many accidents are caused by poorly maintained power tools.

f) Keep cutting tools sharp and clean. Properly maintained cutting tools with sharp cutting edges are less likely to bind and are easier

g) Use the power tool, accessories and tool bits etc. in accordance with these instructions, taking into account the working conditions and the work to be performed. Use of the power tool for operations different from those intended could result in a hazardous situation.

5. Service

a) Have your power tool serviced by a qualified repair person using only identical replacement parts. This will ensure that the safety of the power tool is maintained.

b) If the replacement of the supply cord is necessary, this has to be done by the manufacturer or its agent in order to avoid a safety hazard.

GENERAL POWER TOOL SAFETY WARNINGS

7. Additional Safety and working Instructions

7.1. Dust from materials such as lead-containing coatings, some wood types, minerals and metals can be harmful to one's health and cause allergic reactions, leading to respiratory infections and/or cancer. Materials containing asbestos may only be worked by specialists. Observe the relevant regulations in your country for the materials to be worked.

7.2. Prevent dust accumulation at the workplace. Dust can easily ignite.

8. Additional Safety Warnings for Router Tables

8.1 Read and understand table and router manual and accessory warnings. Failure to follow all instructions and warnings may result in serious personal injury.

8.2 Fully assemble and tighten all fasteners required for this table and for mounting the router to the plate. Do not use the router table until all assembly and installation steps have been completed.

Use the correct table rings in relation to the size of the cutter block.

Check the table and the router to make sure fasteners are still tight before each use. A loose table is unstable and may shift in use.

8.3 Make certain the router is not plugged into a power outlet when installing into the table, removing from table, making adjustments or changing accessories.

Router could accidentally start.

8.4 Do not plug router motor power cord into standard wall outlet. It must be plugged into the router table switch.

Power tool switches and controls need to be within your reach in emergency situations.

8.5 Before operating, make sure the entire unit (table with router installed) is placed on and secured to a solid, flat, level surface and will not tip. Use of auxiliary in-feed and out-feed supports is necessary for long or wide work pieces.

Long work pieces without adequate support can flip off the table or cause the table to tip over.

8.6 Be certain router motor is fully and securely clamped in the router base.

Periodically check the base fastener clamping tightness. Router motor can vibrate loose from the base during use and fall from table.

8.7 Do not use the router table without the overhead guard or auxiliary bit guard. Remove all dust, chips, and any other foreign particles that can affect its function. Adjust the guard height so that it clears the router bit and the work piece. The guard will aid in keeping hands from unintended contact with rotating router bit.

8.8 Never place your fingers near a spinning bit or under the guard when router is plugged in. Never hold the work piece on the out-feed side of bit. Pressing the work piece against the out-feed side of the fence may cause material binding, and possible kickback pulling hand back into bit.

GENERAL POWER TOOL SAFETY WARNINGS

8.9 Guide work piece by the fence to maintain control of work piece. Do not place material between router bit and fence while routing the edge. This placement will cause the material to become wedged, making kickback possible.

8.10 Routers are intended for working with wood, wood-like products and plastic or laminates, not for cutting or shaping metals. Be sure work piece does not contain nails etc. Cutting nails may cause loss of control.

8.11 Do not use bits that have a cutting diameter that exceeds the clearance hole in the table top insert. Bit could contact insert ring, throwing fragments.

8.12 Install bit in accordance with instructions in router manual and securely clamp the router bit in the collet chuck before making any cuts to avoid bit becoming loose during operation.

8.13 Never use dull or damaged bits. Sharp bits must be handled with care. Damaged bits can snap during use. Dull bits require more force to push the work piece, possibly causing the bit to break or the material to kick back.

8.14 The router table is designed to cut flat, straight and squared materials. Do not cut material that is warped, wobbly, or otherwise unstable. If the material is slightly curved but otherwise stable, cut the material with the concave side against the table or fence. Cutting the material with the concave side up or away from table may cause the warped or wobbly material to roll and kick back causing user to lose control.

8.15 Never start the tool when the bit is engaged in the material. The bit cutting edge may grab the material, causing loss of control of the work piece.

8.16 Feed the work piece against the rotation of the bit. The bit rotates anticlockwise as viewed from the top of table. Feeding the work in the wrong direction will cause the work piece to “climb” up on the bit, pulling the work piece and possibly your hands into the rotating bit.

8.17 Use push sticks, vertical and horizontally mounted feather-boards (spring sticks), and other jigs to hold down the work piece. Push sticks, feather-boards, and jigs eliminate the need to hold the work piece near the spinning bit.

8.18 Piloted bits along with the starter pin are used when routing internal and external contours on the work piece. Use the auxiliary bit guard when shaping material with the starter pin and piloted bits. The starter pin and bearing of the piloted bit assist in maintaining control of the work piece.

8.19 Do not use the table as a workbench or work surface. Using it for purposes other than routing may cause damage and make it unsafe to use in routing.

8.20 Never stand on the table or use as a ladder or scaffolding. Table could tip or the cutting tool could be accidentally contacted.

10. Using an Extension Cable.

10.1. We advise this item to not be used with multiple extension leads.

10.2. When using a cable reel, always unwind the cable completely before turning on the saw.



SYMBOLS AND POWER RATING CHART



Danger! – Read the operating instructions to reduce the risk of injury.



Caution! Wear safety goggles.



Caution! Wear ear defenders. The impact of noise can cause damage to hearing.



Caution! Risk of Injury! Do not reach into the running saw blade.



Caution! Wear a dust mask.

MACHINE DETAILS AND PRODUCT FEATURES

Machine Details

Specifications:

Mains Voltage -	230v/50Hz
Power Consumption -	1500w
Min Speed -	8000rpm
Max Speed -	26000rpm
Max Cutting Depth -	38mm
Max Cutter Raise -	40mm
Table Size -	597x457mm
Table Height -	355mm
Gross Weight -	23.0kg
Nett Weight -	19.6kg

Package Contents:

Router Table
Mitre Gauge
Guide Fence
3 x Feather Boards
Tool Wrench
¼" Collet
½" Collet
2 x Leg Storage Boxes

Product Features

1. Extractor Hood
2. Back Guide Fence
3. Mitre Gauge
4. Variable Speed Control
5. on/Off Switch
6. Height Adjustment Handle
7. Collet x2
8. Feather-board
9. Fence Base
10. Hood Screw
11. Hood nut
12. Support Blocks
13. Block Screw
14. Knob Nut
15. Feather-board Screw
16. Large Washer
17. Small Washer
18. Square Washer
19. Back Guide Fence
Screw
20. Flat Feather-board
Screw
21. Spindle Lock
22. Tool Wrench

Intended Use

The power tool is intended as a stationary machine for the cutting of wood or wood based materials when suitable cutter is fitted. It is not intended for continuous production or production line use.

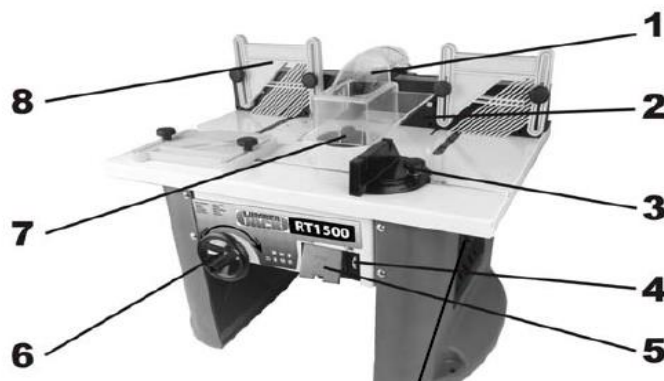

ASSEMBLY

Avoid unintentional starting of the machine. During assembly and for all work on the machine, the power plug must not be connected to the mains supply.

Carefully remove all parts included in the delivery from their packaging.

Remove all packaging material from the machine and the accessories provided.

Before starting the operation of the machine for the first time, check if all parts listed in the box content section have been supplied.

Note: Check the power tool for possible damage. Before further use the machine, check that all protective devices are fully function. Any lightly damaged parts must be carefully checked to ensure flawless operation of the tool. All parts must be properly mounted and all conditions fulfilled that ensure faultless operation.

Damaged protective devices and parts must be immediately replaced by an authorised service centre.

Back Guide Fence (2) Assembly

– Take Fence Base (9) and extractor hood (1). Align the hood with the centre square hole of the Fence base.

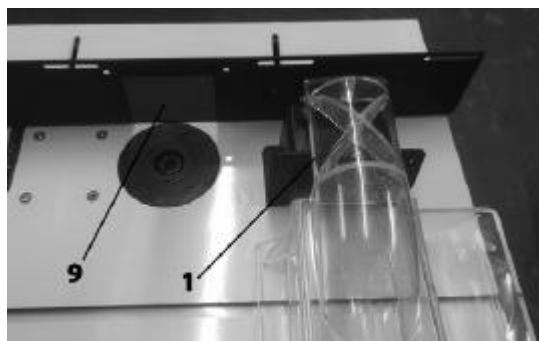

– Secure the hood to the Fence base using 2 x hood screws (10), 2 x small washers (17) and 2 x hood nuts (11).

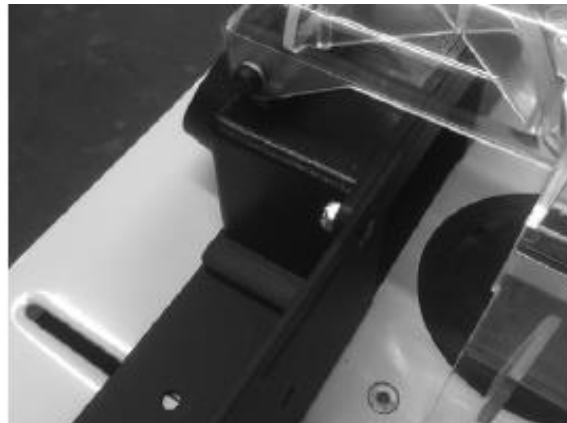

– Take support block (12), and using 2 x block screws (13), 2 x large washers (16) and 2 x knob nuts (14) attach the support block to each side of the hood. **Make sure** that the bevelled edge of each block is next to the hood on either side.

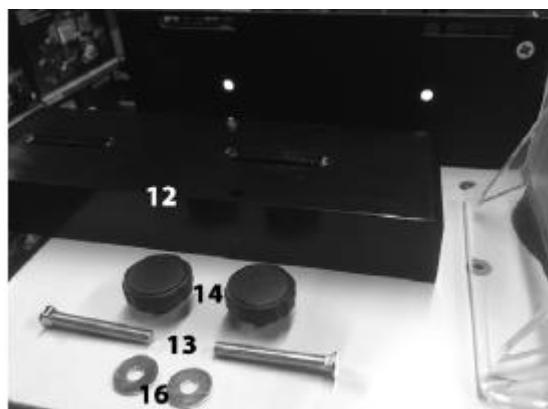

Be aware that the block screws fit the support block (12) to the fence base (9) through the slotted holes in the support block (12) and the circular holes in the fence base (9). Also the knob nuts (14) are used at the back of the fence base (9).

ASSEMBLY

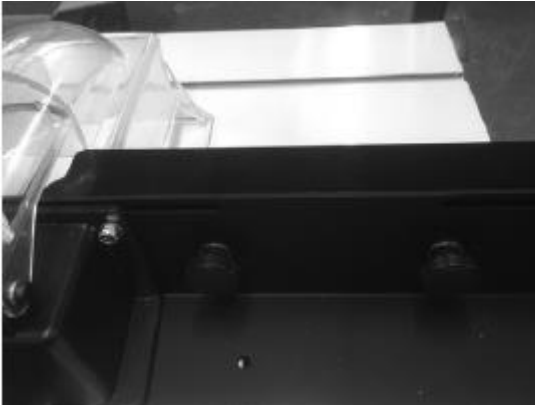

– Attach the feather-boards to each side using 2 x feather-board screws (15), 2 x knob nuts (14) and 2 x large washers (16).

Be aware that the feather-boards (8) attach to the back guide fence (2) through the slotted holes in the fence base (9) and the circular holes in the back support (12). Also the knob nuts (14) are used at the front of the feather-boards (8).

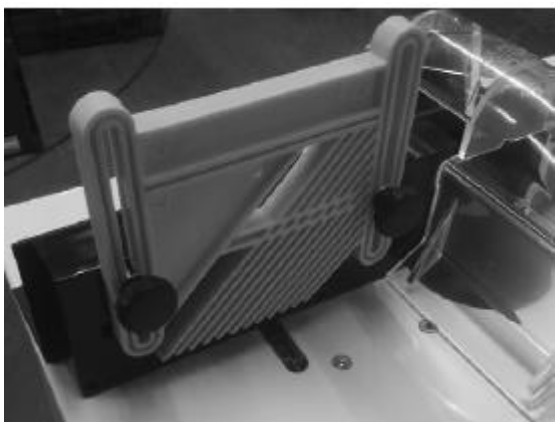
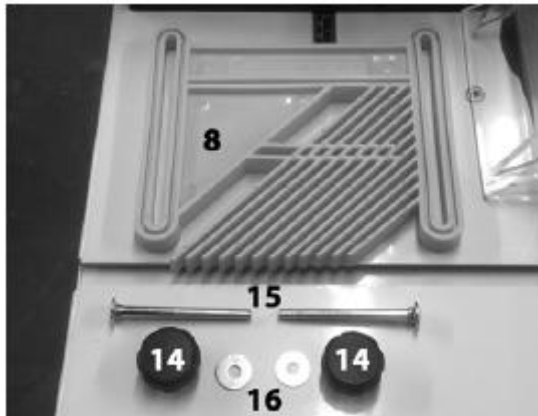

– The above is needed on both sides of the back support

– Attach the built back fence guide (2) to the table top using 2 x back guide fence screws (19), 2 x large washers (16) and 2 x knob nuts (14).

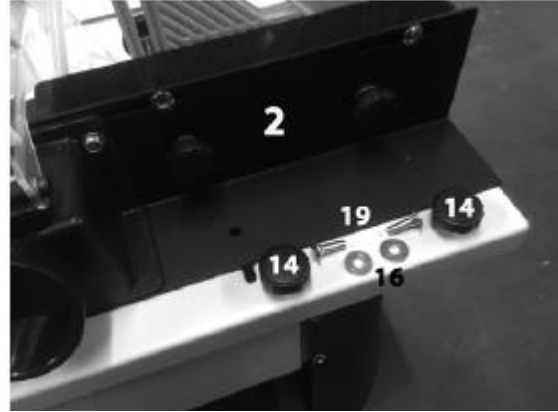

be aware that the screws must be inserted through the slotted hole on the table from underneath so that the knob nuts (14) can be used from the top.



ASSEMBLY

Front Feather-board (8) Assembly

– Attach the front feather-board (8) using 2 x square washers (18), 2 x Flat feather-board screws (20), 2 x large washers (16) and 2 x knob nuts (14). To do this thread the flat feather-board screw (20) with a square washer (18), then thread this through the feather-board (8). Next thread on a large washer (16), and finally loosely thread on knob nut (14).

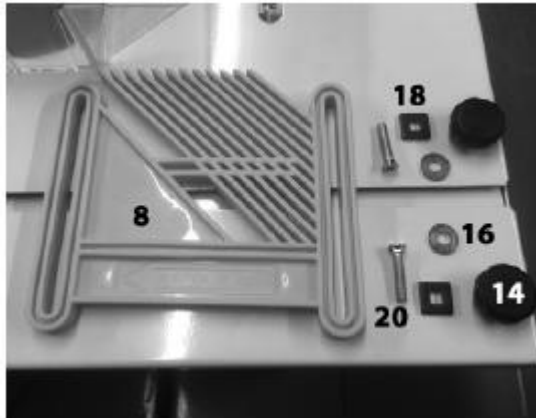

– Complete this for both sides of the feather-board (8). This will then thread neatly through the trench in the table top giving the following result, and a free flowing feather-board (8).

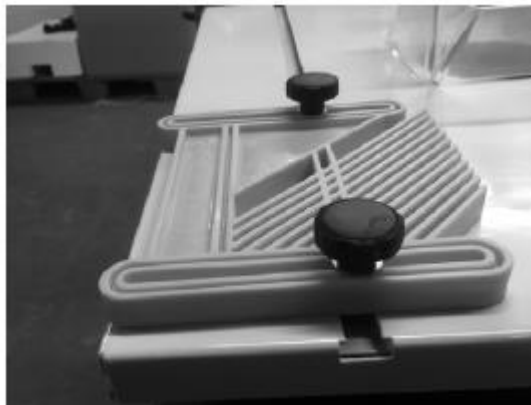

Router Rise and Fall Handle (6) Assembly

– Unscrew the screw for the handle aperture
– Align the Handle (6) with the aperture
Be aware this has a semi-circular design and will only fit on in one way. As such please do not try to force on the handle 6 as it may damage the tool.



– Once pushed on using screwdriver to tighten the screw back up.



Stationary or Flexible Mounting

To ensure safe handling, the machine must be mounted on a level and stable surface (e. g., workbench) prior to using.

ASSEMBLY & OPERATION

Mounting to a Working Surface

- Fasten the power tool with suitable screw fasteners to the working surface. The mounting holes serve for this purpose.
- Clamp the power tool with commercially available screw clamps by the feet to the working surface

Dust/Chip Extraction

Dusts from materials such as lead-containing coatings, some wood types, minerals and metal can be harmful to one's health. Touching or breathing-in the dusts can cause allergic reactions and/or lead to respiratory infections of the user or bystanders. Certain dusts, such as oak or beech dust, are considered as carcinogenic, especially in connection with wood-treatment additives (chromate, wood preservative). Materials containing asbestos may only be worked on by specialists.

- Always use dust extraction
 - Provide for good ventilation of the working place.
 - It is recommended to wear a P2 filter-class respirator.
- Observe the relevant regulations in your country for the materials to be worked. The dust/chip extraction can be blocked by dust, chips or work piece fragments.
- Switch the machine off and pull the mains plug from the socket outlet.
 - Wait until the router bit has come to a complete stop.
 - Determine the cause of the blockage and correct it.

External Dust Extraction

Connect a suitable extractor to the extractor hood (1). Internal diameter 70mm. The dust extractor must be suitable for the material being worked. When vacuuming dry dust that is especially detrimental to health or carcinogenic, use a special dust extractor.

Operation

Be aware you should always make sure that On/off switch (5) is set to the off position and that the tool is not plugged in to any outlet before making any adjustments to the router table.

Installing and Removing the Collet (7).

- Turn the router rise and fall handle (6) so that the collet is set to its maximum height.
- Pull spindle lock (21) to engage the mechanism, and using tool wrench (22) untighten the collet (7) in an anti-clockwise direction.

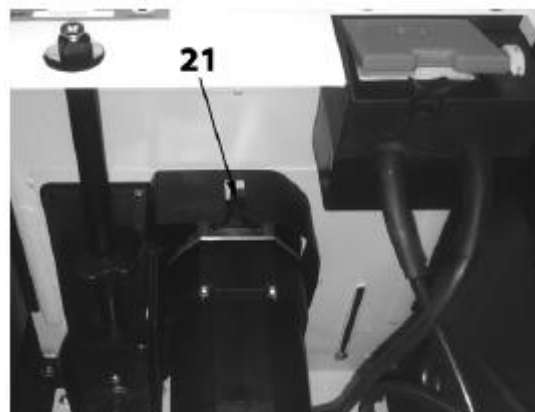

Be aware you will need both hands to achieve this, one hand engaging the spindle lock (21), and one to untighten the collet (7).

OPERATION



- Place new collect (7) on to spindle and finger tighten, with router bit inserted.
- Engage the spindle lock (21), and tighten the collect (7) with the tool wrench (22) in a clockwise direction.

Adjusting the Router Speed



- Simply adjust the variable speed control dial (4), with 1 being the slowest at approx. 8000rpm (no load speed) and 6 being the highest speed at 26000rpm (no load speed).

Be aware using the correct speed for each individual job increases the life of the router bit and can also affect the surface finish on the end piece. We recommend that you make a trial cut with a scrap piece to determine the correct speed.

Do not adjust the speed of the router whilst in use or turned on. Turn off the machine and allow it to come to a complete stop before you adjust the speed.

Operating the Router Table

- To turn on the machine, lift the safety cover and press the green on button.
- To turn off the machine, lift the safety cover and press the red off button.

Using the Table

- Insert and secure the desired collet (7) and router bit.
- Make all necessary adjustments to the router table, feather-boards (8), and back guide fence (2).
- Make sure the on/off switch (5) is set to the off position, and then plug the machine in an outlet.
- Push the on switch.
- Feed the work piece gradually from right to left against the rotation of the cutter. Be sure to keep the feed rate constant for best results.

Be aware feeding the work piece too slowly will cause burn to appear on the piece, and feeding it too quickly will slow the motor and cause an uneven cut. On very hard wood more than one pass may be required at progressively deeper cuts until the depth wanted is achieved.

- When you have finished, push the off switch, allow the machine to come to a full stop, and then unplug the machine from the outlet.

MAINTENANCE AND SERVICE

Be aware that the machine should always have the on/off switch **(5)** set to the off position and be unplugged from any outlet before any inspection, adjustments, maintenance or cleaning is performed.

– **Before each use** inspect the general condition of the machine. Check for loose screws, misalignment or binding of moving parts, cracked or broken parts, damaged electrical wiring, loose router bit, and any other condition that may affect its safe operation. If abnormal noise or vibration occurs, have the problem corrected before further use.

– **Each day** remove all sawdust and debris from the router table with a soft brush, cloth or vacuum, making sure that you pay particular attention to the extraction hood **(1)** and the main table. Also lubricate all moving parts with premium lightweight machine oil.

Do not use solvents or caustic agents to clean the router table.

LUMBERJACK GUARANTEE

1. Guarantee

1.1 Lumberjack guarantees that for a period of 12 months from the date of purchase the components of qualifying products (see clauses 1.2.1 to 1.2.8) will be free from defects caused by faulty construction or manufacture

1.2 During this period, Lumberjack, will repair or replace free of charge any parts which are proved to be faulty in accordance with paragraph 1.1 providing that:

1.2.1 You follow the claims procedure set out in clause 2.

1.2.2 Lumberjack and its Authorised Dealers are given reasonable opportunity after receiving notice of the claim to examine the product.

1.2.3 If asked to do so by Lumberjack or its Authorised Dealer, you return the product at your own cost to Lumberjack's or the supplying Authorised Dealer's Premises -

For the examination to take place clearly stating the Returns Material Authorisation Number given.

1.2.4 The fault in question is not caused by industrial use, accidental damage, fair wear and tear, wilful damage, neglect, incorrect electrical connection, misuse, alteration or repair of the product without approval.

1.2.5 The product has been used in a domestic environment only.

1.2.6 The fault does not relate to consumable items such as blades, bearings, drive belts or other wearing parts which can reasonably be expected to wear at different rates depending on usage.

1.2.7 The product has not been used for hire purposes.

1.2.8 The product has been purchased by you, as the guarantee is not transferable from a private sale.

LUMBERJACK GUARANTEE

2. Claims Procedure

2.1 In the first instance please contact the Authorised Dealer who supplied the product to you. In our experience many initial problems with machines that are thought to be fault due to faulty parts are actually solved by correct setting up or adjustment of the machine. A good Authorised Dealer should be able to resolve the majority of these issues much more quickly than processing a claim under the guarantee. If a return is requested by the Authorised Dealer or Lumberjack, you will be provided with a Returns Material Authorisation Number which must be clearly stated on the returned package, and any accompanying correspondence. Failure to provide a Returns Material Authorisation Number may result in item being refused delivery.

2.2 Any issues with the product resulting in a potential claim under the guarantee must be reported to the Authorised Dealer from which it was purchased within 48 hours of receipt.

2.3 If the authorised Dealer who supplied the product to you has been unable to satisfy your query, any claims made under this guarantee should be made directly to Lumberjack. The claim itself should be made in a letter setting out the date and place of purchase, giving a brief explanation of the problem which has led to the claim.

2.4 Please note that it is essential that the letter of claim reaches Lumberjack on the last day of this guarantee at the latest. Late claims will not be considered.

3. Limitation of Liability.

3.1 We only supply products for domestic and private use. You agree not to use the product for any commercial, business or resale purposes and we have no liability to you for any loss of profit, loss of business, business interruption or loss of business opportunity.

3.2 This guarantee does not confer any rights other than these expressly set out above and does not cover any claims for consequential loss or damage. This guarantee is offered as an extra benefit and does not affect your statutory rights as a consumer.

4. Notice

This guarantee applies to all product purchased from an Authorised Dealer of Lumberjack within the United Kingdom. Terms of guarantee may vary in other countries.



CE DECLARATION OF CONFORMITY

TOOLSAVE

Unit C, Manders Ind. Est.,

Old Heath Road, Wolverhampton,

WV1 2RP.

Tel: 01902 450 470

Declares that the ROUTER TABLE (RT1500)

Is in compliance with the regulations included in the Directives:2006/42/EC

EC DECLARATION OF CONFORMITY

Certificate for EC-type examination delivered by TUV Rheinland Product Safety GmbH-Am Grauen
Stein-D-51105 Koln GERMANY (Registration No.:An 50164143 0001)

Person who declares: Bill Evans

CE

30/08/2018

The Director



PARTS LIST

No.	Part. number	Description	QTY
A1	10250027	TABLE COMPONENTS	1
A2	20250002	SLIDING GUIDE	1
A3	50010030	COLUMNED PIN	1
A4	50020019	M6X30 SCREWS	3
A5	10060021	POINTER	1
A6	50040070	M5X6 SCREWS	1
A7	50060015	M6 NUTS	13
A8	30080037	COVER OF SMALL KNOB	13
A9	30080035	BODY OF SMALL KNOB	13
A10	50010084	BIG WASHERS	13
A11	30200016	ANGLE BOARD	1
A12	30200027	FEATHER	3
A13	50020034	M6X70 SCREWS	4
A14	50020033	M6X50 SCRES	4
A15	30140001	BLOCK BOARDS	2
A16	30200005	PROTECTOR	1
A17	50050047	SCREWS	2
A18	30200006	BASE OF PROTECTOR	1
A19	50010035	M6 WASHERS	10
A20	50060023	M6 NYLON NUTS	10
A21	50040068	M5X25 SCREWS	1
A22	10230031	TURNING SHAFT	1
A23	50060022	M5 NYLON NUTS	1
A24	10130041	FENCE FRAME	1

PARTS LIST

No.	Part. number	Description	QTY
A25	10250026	LEADING PIECES	2
A26	50020023	M6X20 SCREWS	2
A27	50040067	M6X16 SCREWS	8
A28	30200003	STANDERS	2
A29	10130003	BACK PANEL	1
A30	30200064	TABLE INSERT	1
A31	10250030	FRONT PANEL	1
A32	50070048	M6X12 SCREWS	8
A33	50010081	M6 SPRING WASHERS	8
A34	50020019	M6X30 SCREWS	2
A35	30200080	Knife Board	2

SWITCH BOX PARTS

No.	Part. number	Description	QTY
C1	30130009	EMREGENCY STOP	1
C2	50040067	M6X16 SCREWS	2
C3	30130006	PLASTIC NAIL	4
C4	30130013	SWITCH BASER	1
C5	50060033	M6 NUTS	2
C6	50230016	ENDING	6
C7	70120007	WIRE (WITH)	1
C8	50230008	PLUG&CONNECTING	4
C9	50230018	BLUE SETS	4
C10	70120009	WIRE (BLUE)	1
C11	70120008	WIRE (BLACK)	1
C12	10380069	INDUCTANCE	1

PARTS LIST

No.	Part. number	Description	QTY
C13	10380069	SIWTCH	1
C14	50220055	CAPACITOR	1
C15	50160007	SPEED CONTROLLER	1
C16	50230028	TERMINAL BLOCK	1
C17	30130005	COVERS	1
C18	50080068	2.9X13 PLASTIC NAIL	8
C19	30070021	PRESSING BOARD	1
C20	30190038	WIRE PROTECTOR	2
C21	50190040	POWER PLUG & CORD	2
C22	10130035	SMALL SPRING	1
C23	30130008	LOCK BASER	2
C24	30130007	LOCK	1
C25	50080104	2.9X13 SCREWS	1

MOTOR PARTS

No.	Part. number	Description	QTY
B1	50010100	M16 RING	2
B2	10130044	WRECH	1
B3	10130033	FIXING CAP	2
B4	10130032	COLLECTOR 1/2 & 1/4	2
B5	10250004	PRESS SPRING	1
B6	10250005	LOCKING PIECES	1
B7	10250006	DUST BLOCKER	1
B8	50070010	M5X12 SCREWS	4
B9	50010022	SPRING WASHER	12
B10	50010034	M5 WASHERS	8
B11	20250001	FORNT COVER	1

PARTS LIST

No.	Part. number	Description	QTY
B12	10250007	PROTECTORS	1
B13	50240075	6004 BEARING	1
B14	50010103	M42 RING	1
B15	10250008	CONNTECTING SETS	1
B16	10250009	RATOR	1
B17	30240025	PRESSING RING	1
B18	50040037	M5X70 SCRES	2
B19	10250010	SPINDLE	1
B20	50240016	6000 2Z BEARING	1
B21	30240031	BEARING FIXING	1
B22	30590003	MOTOR SHELL	1
B23	50040089	M5X55 SCREWS	4
B24	10240051	BURSH BOX	2
B25	10240043	CARBON BURSH	2
B26	10240042	SPRINGS	2
B27	50080046	ST 4X12 SCREWS	6
B28	30240024	BACK COVERS	1
B29	30590004	INNER NUT	1
B30	30590001	CONNTECTORS	1
B31	30590002	OUTER NUT	1
B32	50230008	PLUG&CONNECTING	2
B33	50230018	BLUE SERS	2
B34	70122257	CONNECTING WIRE	1
B35	50040046	M6X55 SCREWS	1
B36	30060019	HANDLES	1
B37	50060033	M6 NUTS	1
B38	30070015	HAND WHEELS	1
B39	50050019	M6X12 SCREW	1



PARTS LIST

No.	Part. number	Description	QTY
B40	10250024	ADJUSTING PARTS	1
B41	50010035	WASHER M6	12
B42	50060023	M6 NYLON NUTS	4
B43	50010023	M6 SPRING WASHERS	1
B44	50030019	M6X12 SCREWS	1
B45	10250031	SHAFT	1
B46	30250001	LOCKING HANDLE	1
B47	50040020	M5X6 SCREWS	8
B48	10250025	FIXER PARTS	1
B49	10060108	GEAR A	1
B50	10250017	LONG POLE	1
B51	50010050	M17 RING	1
B52	50040023	M5X12 SCREWS	2
B53	50030060	M6X8 SCREWS	1
B54	50030095	M6X10 SCREWS	4
B55	50240048	61093 BEARING	1
B56	10250020	BEARING COVERS	1
B57	10250019	GEAR B	1
B58	50060022	M5 NYLON NUTS	2
B59	10250021	GEAR COVER	1
B60	50230016	ENDING	2

PARTS DIAGRAM

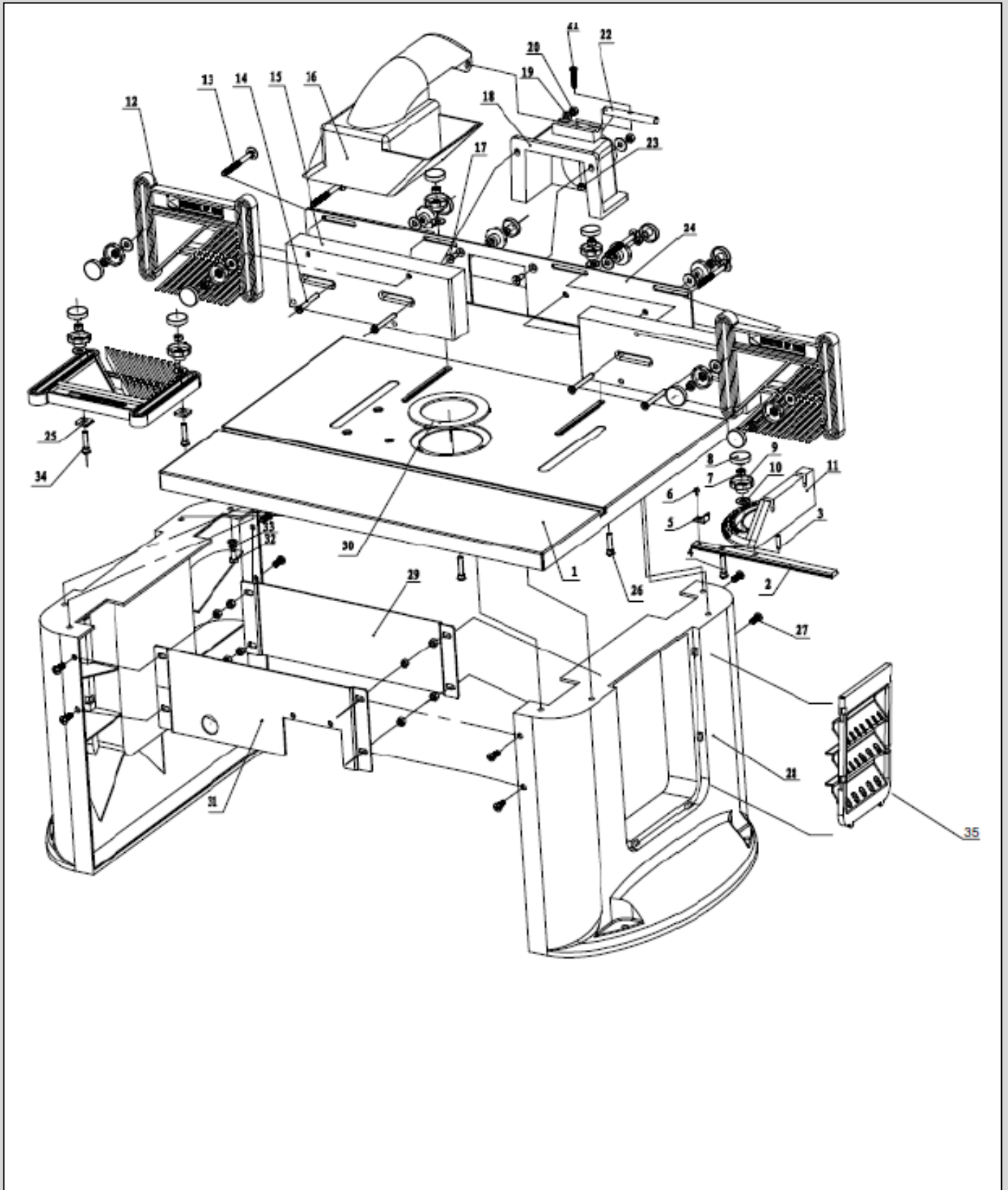

PARTS DIAGRAM SWITCH BOX

