

PLANER / THICKNESSER

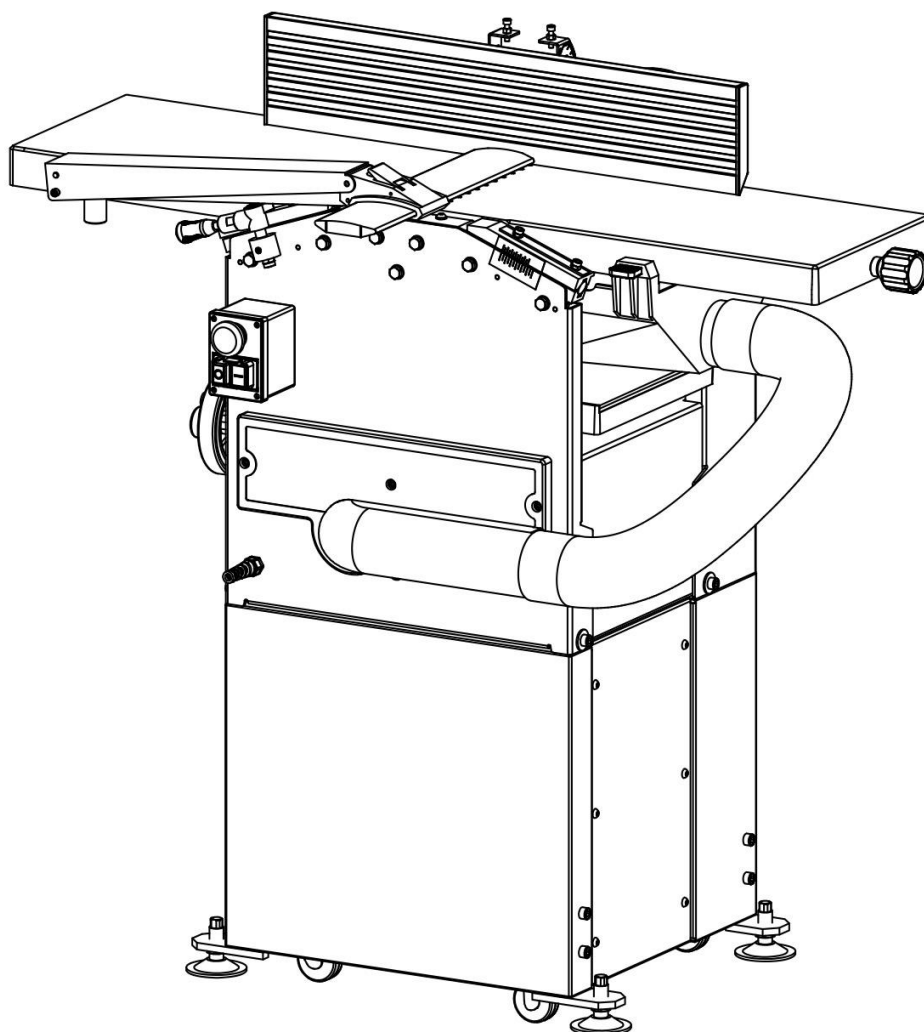

ORIGINAL INSTRUCTIONS

Technical Specification

Planer / Thicknesser	PT305
Voltage/frequency:	230V / 50Hz
Motor Power	1800 W
Cutting block speed	6700 1/min
Cutting blades	2
Planer	
Max. planing width	305 mm
Max chip removal	3 mm
Fence L X H	635X127 mm
Surfacing table size	1075X305 mm
Thicknesser	
Max. planing width	305mm
Max. planing thickness	160 mm
Max. chip revol	2 mm
Thicknessing table size	500 X 305 mm

SAFETY INSTRUCTIONS

WARNING: When using electric tools, basic safety precautions, including the following, should always be followed to reduce the risk of fire, electric shock and personal injury. Read all these instructions before operating this product and save the instructions.

CAUTION: Read and follow all Safety Rules and operating Instructions before First Use of this Product. Keep this manual with tool.

GENERAL SAFETY INSTRUCTIONS

Hand on these safety notes to all people working on the machine. The instructions must be read by every operator before starting work. During the work, it is too late. This is especially applicable to personnel not working regularly on the machine, for instance when doing preparation, adjusting or servicing work.

- Observe all safety instructions and warnings attached to the machine
- See to it that safety instructions and warnings attached to the machine are always complete and perfectly legible.
- Check all power supply lines. Do not use defective lines.
- Make sure that the machine is set up in a stable position on firm ground.
- Take care that there is sufficient light on and around the machine.
- Be careful when working: Risk of injury for fingers and hands through the rotating cutting tool.
- When working on the machine, all guards and covers must be fitted and in working position.
- Keep other people, especially children, away from the working area and from the machine when it is connected to the power supply.
- Make sure children cannot touch the machine not in use.

- Do not overload the machine and only use it within the performance range specified in the chapter Technical Data of the operating manual.
- When working outside, do not stand on slippery ground and wear solid shoes.
- Do not misuse the cable. Protect it from heat, oil, and sharp edges.
- Only use well-sharpened planing knives for better and safe work.
- Maintain the handles dry, clean and free from oil and grease.
- Before switching on the machine, remove all keys and setting tools.
- When working outside, only use the correctly marked and authorized extension cable.
- Keep other people, especially children, away from the machine when it is connected to the power supply.
- Be attentive and pay attention to what you are doing. Use your good sense and do not work with the machine when you are not concentrated.
- Persons working on the machine may not be diverted from their work.
- The working space on the machine must be free of chips and wood scrap. Disorder can cause accidents.
- Protect the machine from rain and moisture.
- Do not use the machine in a humid or wet environment.
- Store the machine in a safe place, so that nobody can get injured or switch on the machine. Make sure that the machine is not parked in the open or in a humid environment without protection.
- Only use the machine according to instructions and to the purpose it has been designed for.
- Do not use the machine where there is a risk of fire or explosion.
- When working with the machine, do not touch any earthed parts (e.g. tubes, radiators, electric stoves, coolers).
- Wear only close-fitting clothes. Remove rings, bracelets and other jewelry.
- Wear ear protection, goggles and a dust protection mask.
- To protect long hair, wear a cap or hair net.
- For changing the planer/thicknesser blades, wear solid gloves.
- Do not wear any gloves for working on the machine, with the exception when handling rough work pieces.
- The safety mechanisms on the machine may not be removed or rendered unusable. Cleaning, changing, calibrating, and setting of the machine may only be carried out when the motor is switched off. Pull the power supply plug and wait for the rotating tool to completely stop.
- Only a qualified electrician is permitted to connect the machine and complete repairs on its electrical equipment.
- After completion of repair or maintenance work, immediately refit all guards and safety devices.
- Before doing any repair work, switch off the machine and pull the power plug.
- Do not use any planer/thicknesser blades showing cracks or having changed their shape.
- Use suitable supports when handling heavy or bulky work pieces, for instance roller stands (optional equipment).
- Cut off the external power supply of the machine even if only minor changes of place are envisaged. Properly reconnect the machine to the supply mains before recommissioning.
- When leaving the work place, switch the motor off. Pull the power supply plug
- Pull the power supply plug when the machine is not in use.
- Before every use, check the machine for any defective switches, plugs, electric cables and defective or missing guards. Only switch on the machine if all parts are in perfect working order.
- Only use well sharpened planing blades. Blunt blades increase the risk of backlash.

- Always match the planer/thicknesser block protector to the work piece width. The unused part of the knife block must be covered.
- Use a feed stick for short work pieces.
- When planing narrow work pieces, use additional supports like, for instance, horizontal pressure devices or spring-loaded guards.
- Do not use the machine for rebating and dovetailing.
- Check the function of backlash and the cutter block regularly.
- Regularly check the firm seat of the planer/thicknesser blades and blade support on the knife shaft.
- The blades must not protrude beyond the knife shaft by more than 1 mm + 10 %.
- The machine must be earthed safely. The yellow/green (green) lead is the earth conductor.
- Regularly check the good function of the backlash safety device.

PROPER USE

- The machine meets the requirements of the valid EC machine directive.
- Before starting to work, all guards and safety devices must be fitted to the machine.
- The machine has been designed to be operated by one person. The operator is responsible opposite third parties for all dangers emanating from the machine in the working area.
- Observe all safety instructions and warnings attached to the machine.
- See to it that safety instructions and warnings attached to the machine are always complete and perfectly legible.
- The planer/thicknesser with its tools and accessories offered has exclusively been designed for the treatment of wood.
- Larger work pieces that could tilt from the table top, require the use of a table length extension or a roller stand (optional equipment).
- Never switch off or remove dust extractor units with the main machine running.
- The machine must only be used in technically perfect condition in accordance with its designated use and the instructions set out in the operating manual. Any functional disorders, especially those affecting the safety of the machine, should therefore be rectified immediately.
- The safety, working and maintenance instructions of the manufacturer, as well as the dimensions stated in the chapter Technical Data, must be observed.
- Relevant accident prevention regulations and other, generally recognized safety-technical rules must also be adhered to.
- The machine may only be used, maintained, and operated by persons familiar with it and instructed in its operation and procedures. Arbitrary alterations to the machine release the manufacturer from all responsibility for any resulting damage.
- The machine may only be used with original accessories and original tools of the manufacturer.
- Attention: The use of other tools or accessories than stated in the operating instructions, can hold the risk of injuries.
- Any other use exceeds authorization. The manufacturer is not responsible for any damages resulting from unauthorized use; risk is the sole responsibility of the operator.

REMAIN HAZARDS

The machine has been built using modern technology in accordance with recognized safety rules. Some remaining hazards, however, may still exist.

- The rotating planing spindle can cause injuries to fingers and hands if the work piece is incorrectly fed.
- Thrown work pieces can lead to injury if the work piece is not properly secured or fed, such as working without a limit stop.
- Wood chips and sawdust can be health hazards. Be sure to wear personal protective gear such as safety goggles and a dust mask. Use a vacuum exhaust system.
- Injuries through defective planer/thicknesser blades. Check the blades regularly for their perfect condition.
- Risk of injuries to finger and hands when changing the planer/thicknesser blades. Wear suitable gloves.
- Risk of injuries through the starting planer/thicknesser blades when switching on the machine.
- Injuries caused by electricity through the use of damaged extension cables.
- Health hazards through the running tool with long hair and loose clothes. Wear personal protective gear like a hairnet and closefitting clothes.
- Even when all safety measures are taken, some remaining hazards which are not yet evident may still exist.
- Remaining hazards can be minimized by following the instructions in "Safety Precautions", "Proper Use", and in the entire operating instructions.

ELECTRICAL REQUIREMENTS

WARNING: To avoid electrical hazards, fire hazards, or damage to the tool, use proper circuit protection. Use a separate electrical circuit for your tools. To avoid shock or fire, if power cord is worn or cut, or damaged in any way, have it replaced immediately.

GROUNDING INSTRUCTIONS

WARNING: This tool must be grounded while in use to protect the operator from electrical shock.

IN THE EVENT OF A MALFUNCTION OR BREAKDOWN, grounding provides a path of least resistance for electric current and reduces the risk of electric shock. This tool is equipped with an electric cord that has an equipment-grounding conductor and a grounding plug. The plug **MUST** be plugged into a matching receptacle that is properly installed and grounded in accordance with ALL local codes and ordinances.

DO NOT MODIFY THE PLUG PROVIDED. If it will not fit the receptacle, have the proper receptacle installed by a qualified electrician.

IMPROPER CONNECTION of the equipment-grounding conductor can result in risk of electric shock. The conductor with green insulation (with or without yellow stripes) is the equipment-grounding conductor. If repair or replacement of the electric cord or plug is necessary, **DO NOT** connect the equipment-grounding conductor to a live terminal.

CHECK with a qualified electrician or service person if you do not completely understand the grounding instructions, or if you are not sure the tool is properly grounded.

Refer to nether picture:

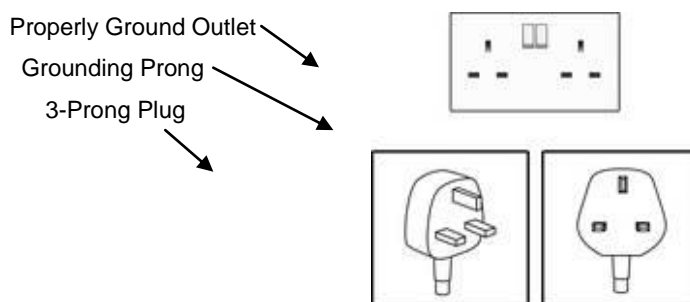

WARNING: Improper connection of equipment grounding conductor can result in the risk of electrical shock. Equipment should be grounded while in use to protect operator from electrical shock.

WARNING: This machine is for indoor use only. Do not expose to rain or use in damp locations.

GUIDELINES FOR EXTENSION CORDS

USE PROPER EXTENSION CORD. Make sure your extension cord is in good condition. When using an extension cord, be sure to use one heavy enough to carry the current your product will draw. An undersized cord will cause a drop in line voltage, resulting in loss of power and cause overheating.

Be sure your extension cord is properly wired and in good condition. Always replace a damaged extension cord or have it repaired by a qualified person before using it. Protect your extension cords from sharp objects, excessive heat and damp or wet areas.

Attention: There is an overload protection device in the circuit.

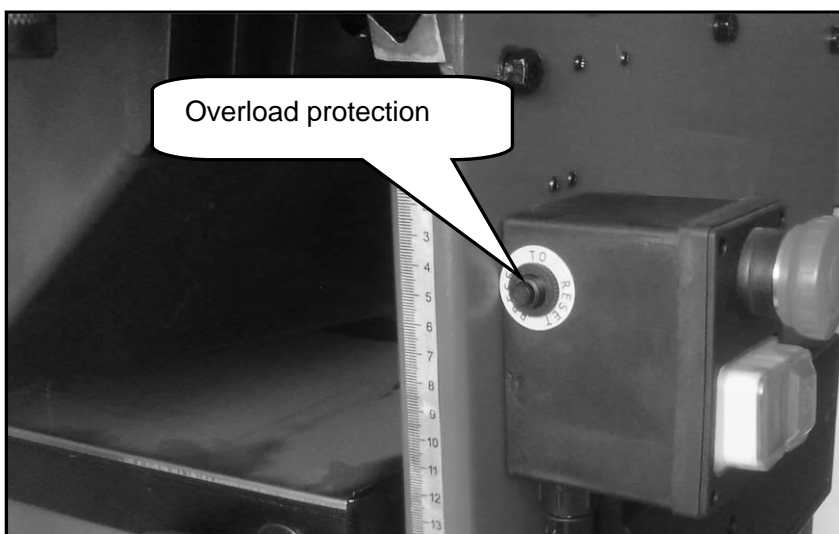

ACCESSORIES AND ATTACHMENTS

RECOMMENDED ACCESSORIES

To avoid injury:

- Use only accessories recommended for this machine.
- Follow instructions that accompany accessories. Use of improper accessories may cause hazards.
- Use only accessories designed for this machine to avoid injury from thrown broken parts or workpieces.
- Do not use any accessory unless you have completely read the instruction or operator's manual for that accessory.

CARTON CONTENTS

UNPACKING AND CHECKING CONTENTS

Carefully unpack the machine and all its parts.

WARNING:

- To avoid injury from unexpected starting, do not plug the power cord into a power source receptacle during unpacking and assembly. This cord must remain unplugged whenever you are assembling or adjusting the machine.
- If any part is missing or damaged, do not plug the machine until the missing or damaged part is replaced, and assembly is complete.

TABLE OF LOOSE PARTS

Unpack carton; check you machine to see parts listed below:

- | | |
|-----------------------------------|----|
| 1. Planer and thicknesser | x1 |
| 2. Fence | x1 |
| 3. Hose | x1 |
| 4. Hose clamp | x2 |
| 5. Push stick | x1 |
| 6. Fence support | x1 |
| 7. Suction connector | x1 |
| 8. Conversion port | x1 |
| 9. Chip bag connector | x1 |
| 10. Lock handle | x1 |
| 11. Bolt with washer | x2 |
| 12. Clamp | x1 |
| 13. Chip bag | x1 |
| 14. Box base | x1 |
| 15. Front caster support assembly | x1 |
| 16. Connecting lever | x1 |
| 17. Rear caster support assembly | x1 |
| 18. Swivel casters | x2 |
| 19. Rigid casters | x2 |
| 20. Hardware bag (not shown) | x1 |

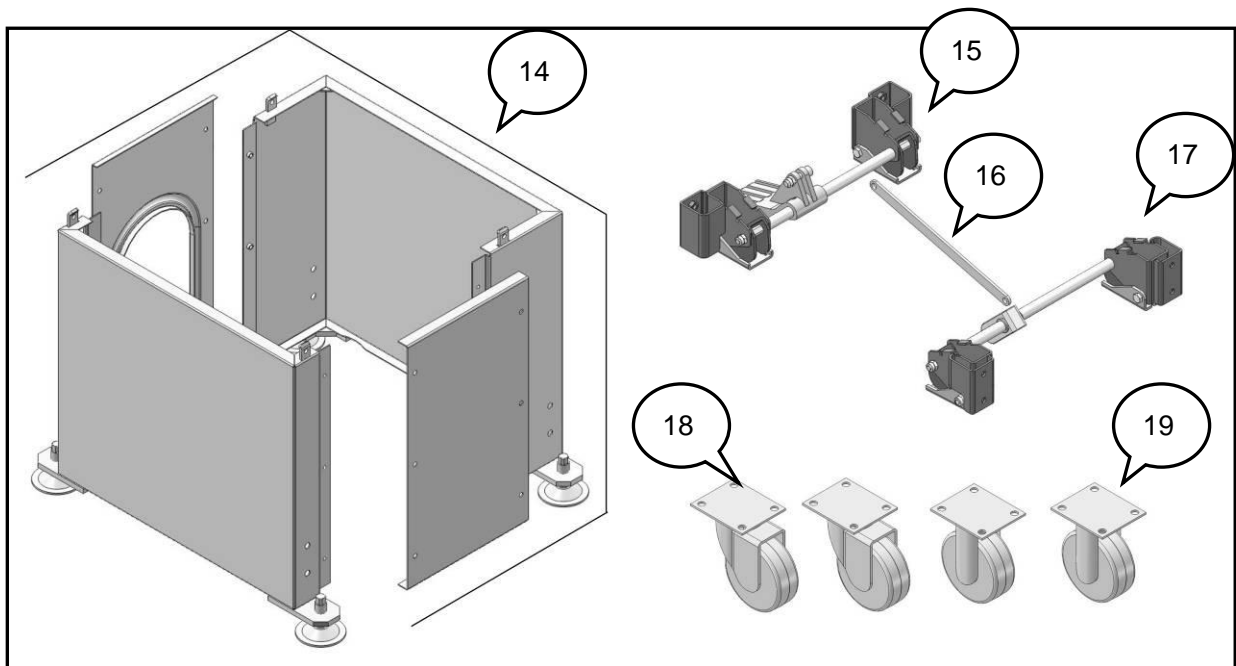
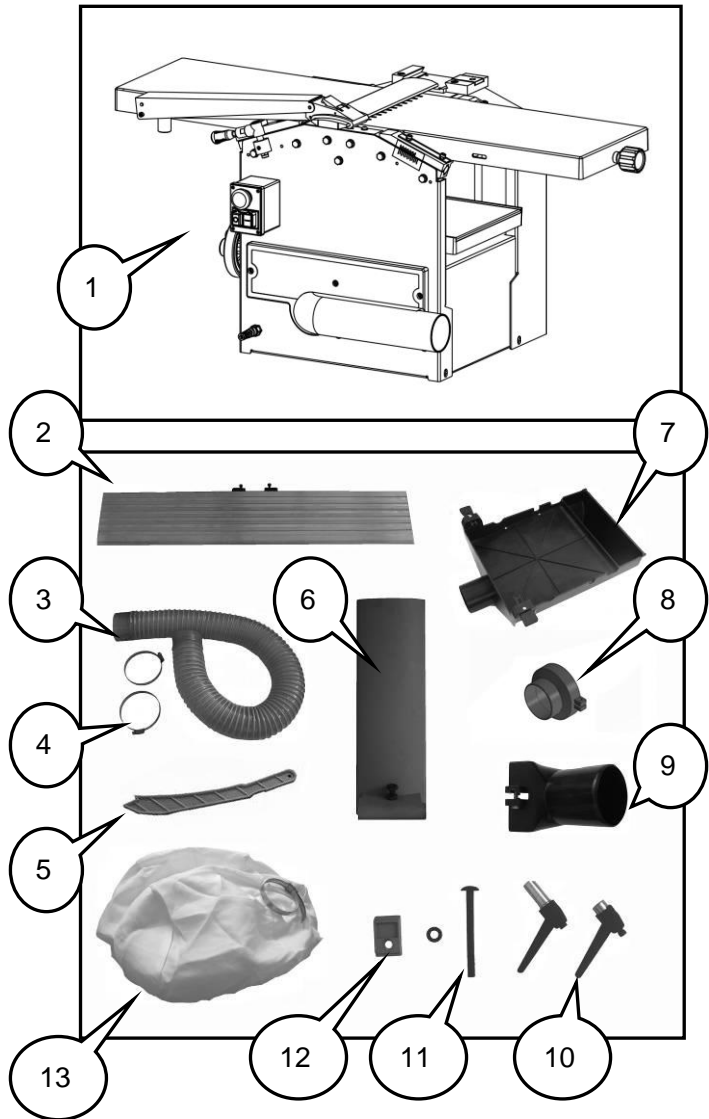

ASSEMBLY & INSTALLATION

WARNING: Do not connect to power supply until assembly is complete. Failure to comply could result in accidental starting and possible serious personal injury.

- Assemble the box base by using 12 socket head bolts **(A)**.
Use socket head screws and flat washers mounting two swivel casters to front caster support assembly. Use socket head screws and flat washers mounting two rigid casters to rear caster support assembly.

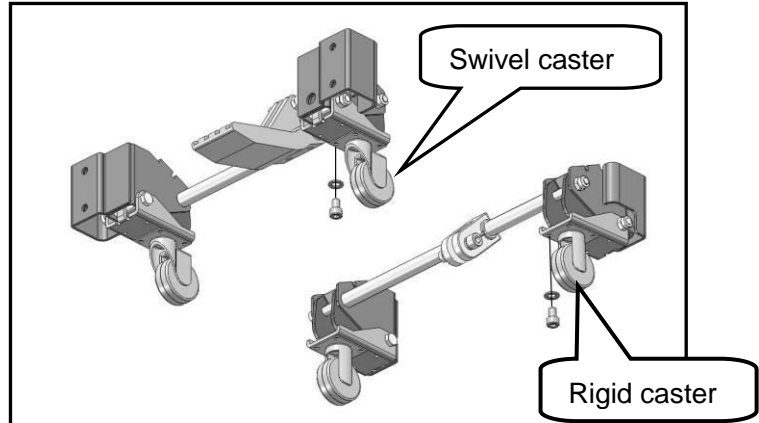
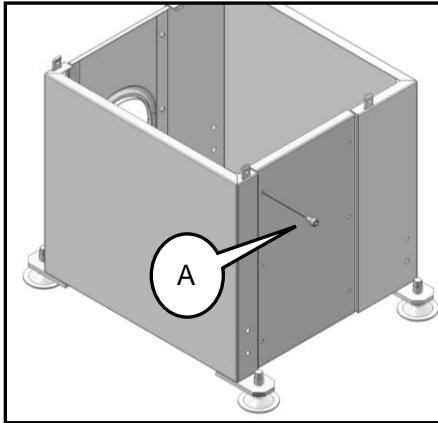

Attach the front and rear caster support assembly to box base, and fix them using with socket head screws.

Use the connecting lever to connect the front and rear caster support. Place the stand assembly on the ground; adjust the foot height if needed.

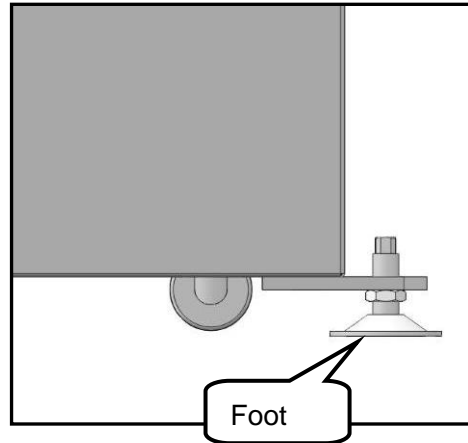
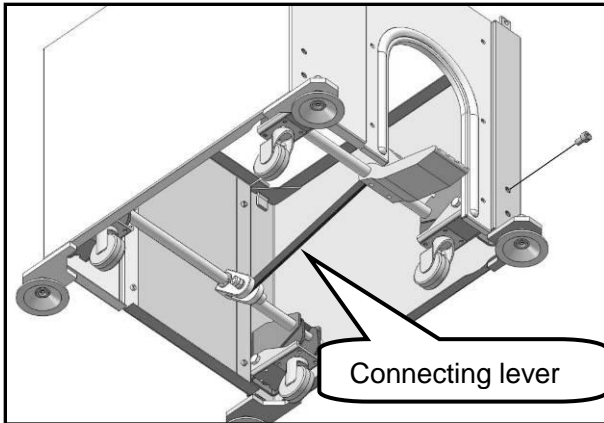

Fit the planer/thicknesser on the box base with help of another person. Fix the machine on the box base using screws and washers **(B)**. Mount the machine to the floor using four screws.

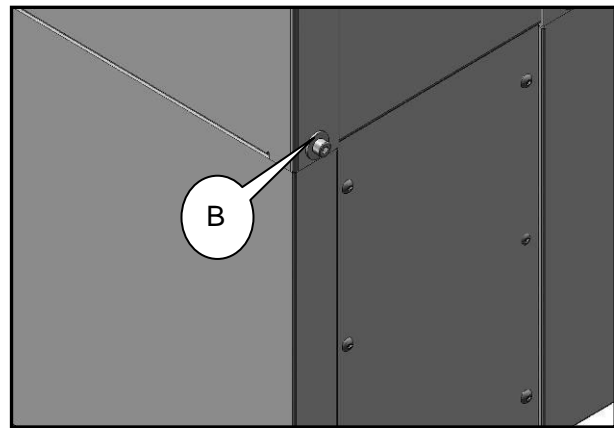
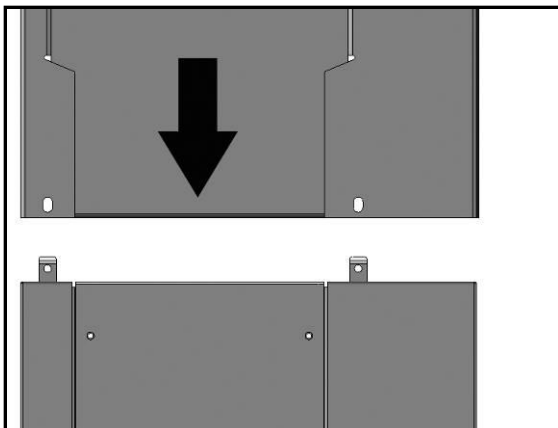

- Insert the fence support **C** in the guide of machine, secure it using short lock handle **D** and clamp **E**.
Assemble the fence to the fence support, fix these with the long lock handle **F**, the bolt and washer.

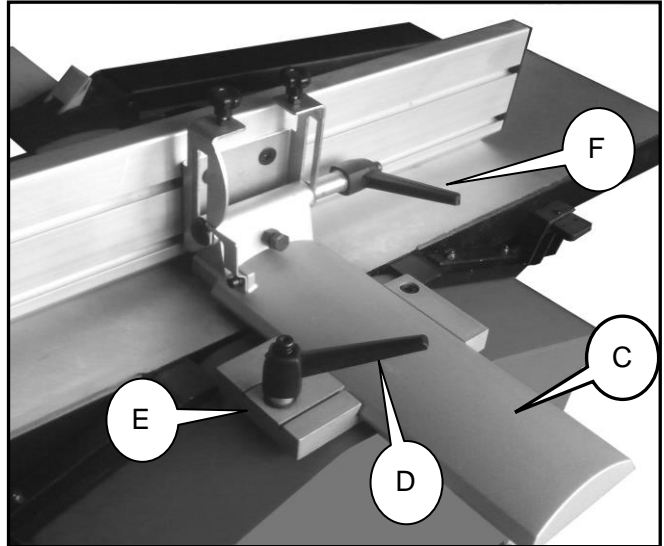

- Fix the chip bag and chip bag connector to the export of dust collector.



ATTENTION:

Make sure there is sufficient space to allow safe and trouble-free working.

Make sure there is sufficient space for handing the workpiece over the whole length without any persons having to stand in line with the workpiece.

OPERATION

Observe the safety instructions and symbols on machine before operation

1. Surfacing

- Mount the suction connector for surface planing.
Rotate the handwheel **G**, set the thickening table to lowest position.
Insert the suction connector under the infeed planing table and fix the two switch pin **H**.
Assemble the conversion port to suction connector, Connect the conversion port with the entry of dust collector using hose and hose clasper.

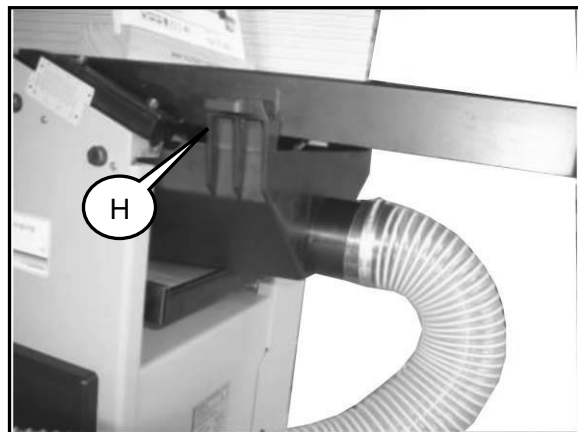
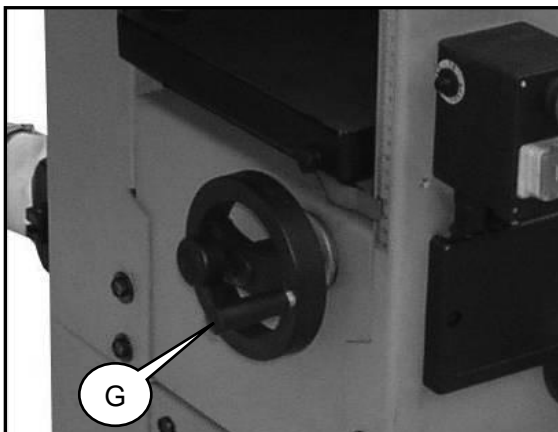

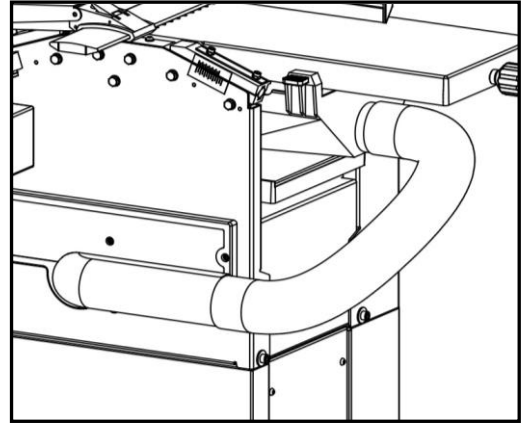
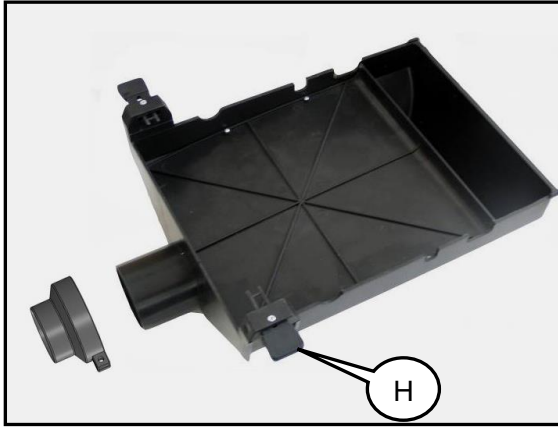

- Adjust the cutter block guard.
The height can be adjusted with the knurled screw **I**, located under the cutter block guard arm. After releasing the locking knob **J**, the cutter block guard can be moved to the side and the planer adjusted to the correct width. After adjusting, tighten the locking knob.

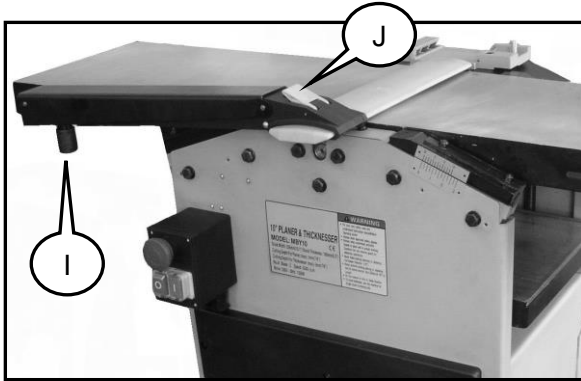

- Loosen the lock handle **D**, you can displace the fence assembly to desired position. Loosen the lock handle **F** to set the angle of fence. Rotate the knob **K** for adjusting the amount of chip removal.

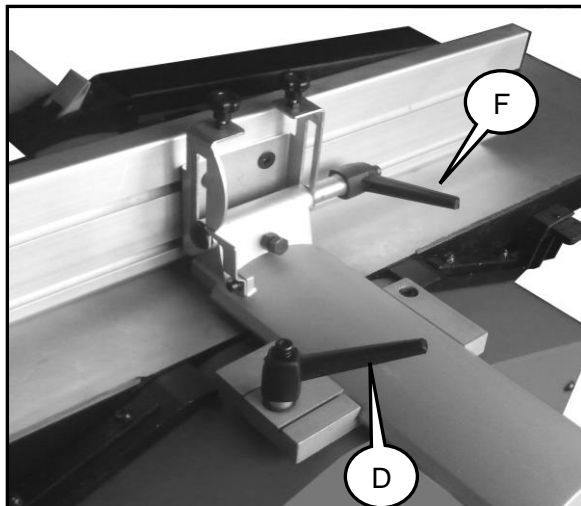

- For planing: Turn on the machine, carefully lead the workpiece onto the cutter block.
Warning: The part of the cutter block not used must be covered by the guard. Working position is in front of the machine at the side of the infeed table. Put the fingers of both hands on top of the work piece. Do not hold the work piece edges. The work pieces to be planed must lie firmly on the table so they can be guided safely. For short work pieces use a push stick.

2. Thicknessing

- Mount the suction connector for thicknessing
Loosen the lock hand **D**, remove the fence assembly.
Pull and rotate the handle **L** to release the table locking, and turn the table over.
Mount the suction connector on the infeed table and fix the two switch pin.
Connect the export of suction connector with the entry of dust collector using hose and hose clammer.

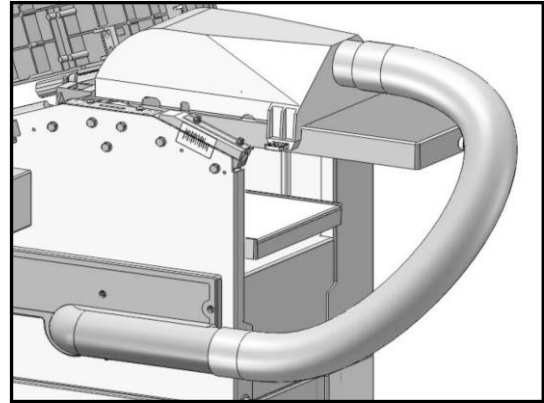
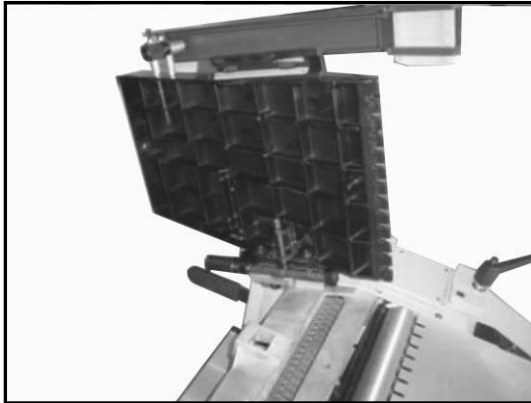
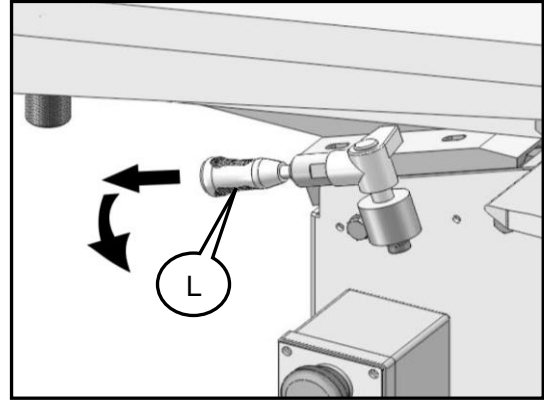

- Set the roller controlled lever **M** to roller working position.
Following the scale and using the handwheel, set the thicknessing table to the desired height.
Narrow wood is introduced in the centre.

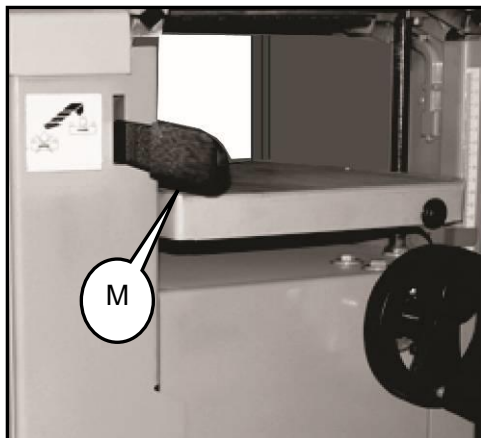

Warning: In case of a defect, switch off the machine at once. Do not remove any chips or splinters from the tables while the machine is running. Work pieces below 250 mm may not be planed.

MAINTENANCE

Warning: Turn off the machine and disconnect from the power supply before conducting maintenance work or settings.

Changing the blades

- Put the main switch of the machine to OFF position.
- Pull the power supply plug from the socket.
- Block the cutter block guard in the lifted position.
- Release the blade clamping screws.
- Lift the blades and blade clamber from the cutter block.
- Remove the chips and any resin from the cutter block and blade clamber.
- Place new blades into the cutter block
- Place the blade clamber onto the blade.
- Slightly tighten the clamping bolts.
- Repeat these actions for the second blade.
- Then adjust the planer/thicknesser blade exactly with the out-feed table **N**. Use a ruler that you put onto the out-feed table.
- By turning the cutter block and using the ruler, you can see the height adjustment.
- The blade is exactly set, when the ruler is moved by the blade not higher than 3 mm.
- After a successful blade setting, all clamping screws must be tightened (8.5 N/m).

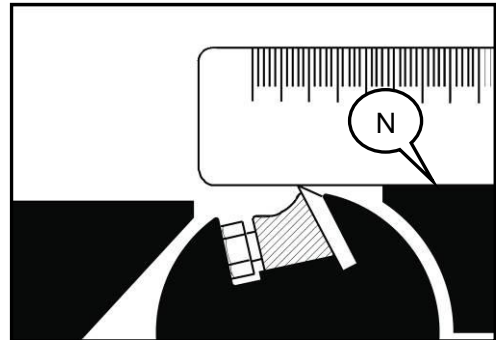

ATTENTION:

- The planer/thicknesser blades used on this machine are not suitable for rebating and dovetailing.
- Finally lower the cutter block guard again onto the table. Cover the cutter block.

Machine care

The planer/thicknesser requires little maintenance. The ball bearings are permanently lubricated. After approx. ten operating hours, lubrication of the following parts is recommended:

- Bearing of the in-feed and output roller
- Bearing of pulley and sprocket

The threaded spindle for height-adjustment of the thicknessing table may only be treated with a dry lubricant agent.

The table surfaces as well as the in-feed and output rollers must always be kept free from resin.

- Regularly clean in-feed and output rollers.
- In order to avoid overheating of the motor, regularly check the air openings for any dust sticking on.

Tool care:

- Cutter block, clamping devices and blades must be regularly cleaned from resin, as a clean tool improves the planing quality.
- Resin from aluminum tools may only be removed with cleaning liquids not being aggressive to this type of metal.

TROUBLESHOOTING

PROBLEM	CAUSE	SOLUTION
Machine cannot be switched on.	<ul style="list-style-type: none"> ● No power supply. ● Circuit breaker is tripped ● Carbon brush worn. 	<ul style="list-style-type: none"> ● Check power supply. ● Reset circuit breaker ● Take machine to your service point.
Machine switches automatically off during idle run.	<ul style="list-style-type: none"> ● No mains supply. 	<ul style="list-style-type: none"> ● Check fuses. ● Due to the integrated low voltage protection, the machine does not restart automatically. Upon return of the voltage, the machine must be switched on again.
Machine stops during planing.	<ul style="list-style-type: none"> ● Overload protection reacts due to blunt knives, infeed too fast, or chip removal too thick. 	<ul style="list-style-type: none"> ● Before work is continued, replace knives or let cool down the motor. Reset the overload protection
Response of the overload protection.	<ul style="list-style-type: none"> ● Too much chip removal ● Too fast feed ● Blunt knives 	<ul style="list-style-type: none"> ● Before work is continued, replace knives or let cool down the motor. Reset the overload protection
Planed surface not smooth.	<ul style="list-style-type: none"> ● Infeed too fast. ● Blunt knives. ● Irregular feed. 	<ul style="list-style-type: none"> ● Reduce infeed speed. ● Replace blades. ● Apply constant pressure and reduce feed.
<i>Rpm drops during planing.</i>	<ul style="list-style-type: none"> ● Chip removal too important. 	<ul style="list-style-type: none"> ● Reduce chip removal.

ASSEMBLY DIAGRAM

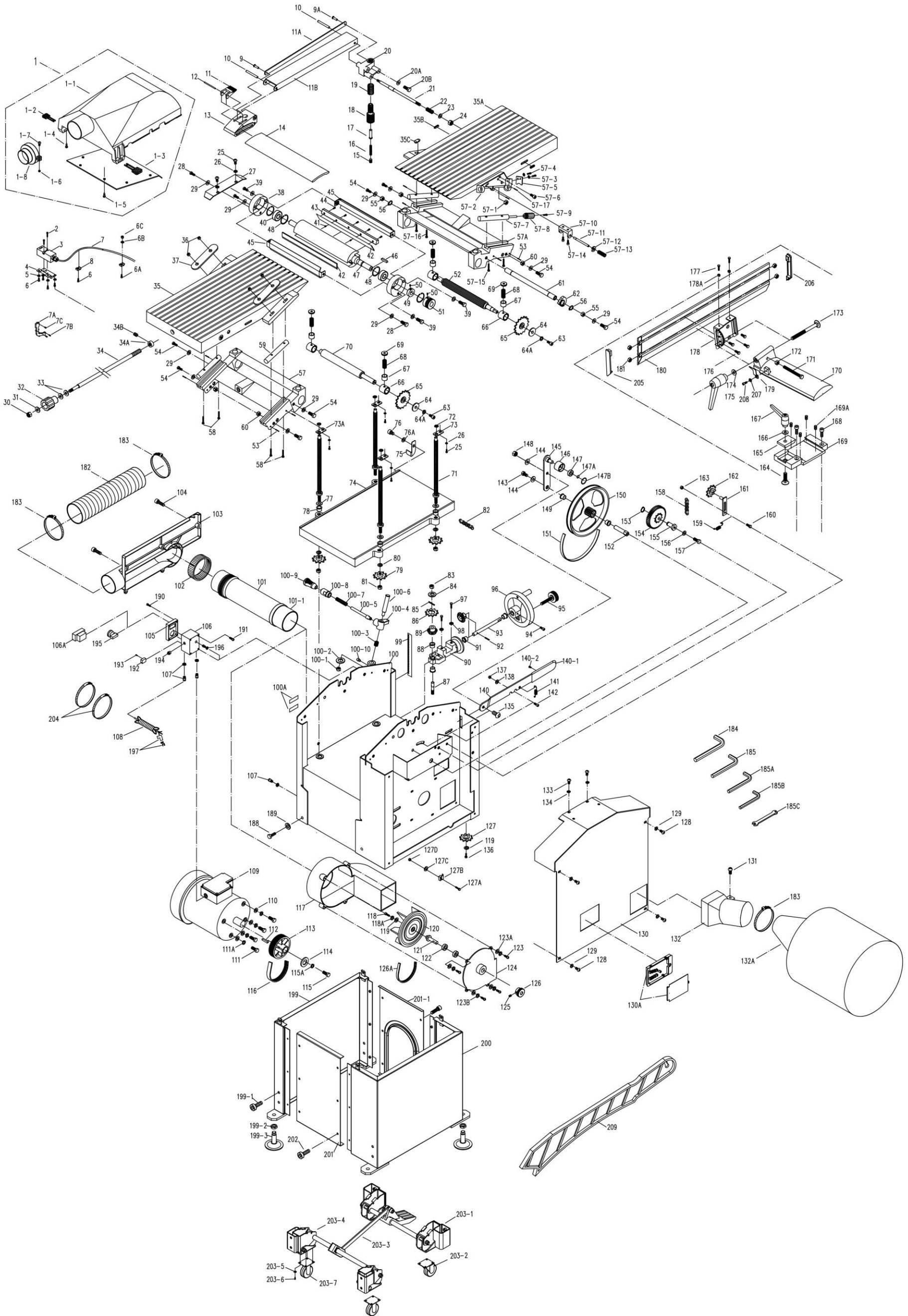

CE DECLARATION OF CONFORMITY

TOOLSAVE

Unit C Manders Ind Est
Old Heath Rd
Wolverhampton,
West Midlands,
WV1 2RP,
ENGLAND.
Tel: 01902450470

Declares that the 10" Planer Thicknesser PT305

Is in compliance with the regulations included in the Directives: 2006/42/EC

EC DECLARATION OF CONFORMITY

Certificate for EC-type examination delivered by Interk Testing Services Hangzhou 16
No. 1 Ave., Xiasha Economic Development District, Hangzhou 310018, China
(Verification No.: 151000179HZH-V1)

Person who declares: Bill Evans

CE

**12.02.2019
The Director**



LUMBER JACK

LUMBERJACK TOOLS
UNIT C MANDERS IND ESTATE
WOLVERHAMPTON
WV1 2RP
UNITED KINGDOM

WWW.LUMBERJACKTOOLS.CO.UK