

ORIGINAL INSTRUCTIONS



TABLE OF CONTENTS

Welcome to Lumberjack!

Dear customer, Congratulations on your purchase. Before using the product for the first time please be sure to read these instructions for use.

They provide you with all information necessary for using the product safely and to ensure its long service life.

Closely observe all safety information in these instructions!

General Power Tool Safety Warnings.....	01
Symbols & Cable Rating Chart	04
Machine Details and Product Features.....	05
Assembly.....	07
Operation.....	10
Maintenance and Service & Lumberjack Guarantee.....	12
Declaration of Conformity(PR12).....	14
Parts List(PR12).....	15
Parts Diagram(PR12).....	17
Declaration of Conformity(PR14).....	18
Parts List(PR14).....	19
Parts Diagram(PR14).....	21

GENERAL POWER TOOL SAFETY WARNINGS

WARNING Read all safety warnings and all instructions. Failure to follow the warnings and instructions may result in electric shock, fire and/or serious injury.

Save all warnings and instructions for future reference. The term "power tool" in the warnings refers to your electric (corded) power tool or battery-operated (cordless) power tool.

1. Work area safety

a) Keep work area clean and well lit. Cluttered or dark areas invite accidents.

b) Do not operate power tools in explosive atmospheres, such as in the presence of flammable liquids, gases or dust. Power tools create sparks which may ignite the dust or fumes.

c) Keep children and bystanders away while operating a power tool. Distractions can cause you to lose control.

2. Electrical safety

a) Power tool plugs must match the outlet. Never modify the plug in any way. Do not use any adapter plugs with grounded power tools. Unmodified plugs and matching outlets will reduce risk of electric shock.

b) Avoid body contact with grounded surfaces, such as pipes, radiators, ranges and refrigerators. There is an increased risk of electric shock if your body is grounded.

c) Do not expose power tools to rain or wet conditions. Water entering a power tool will increase the risk of electric shock.

d) Do not abuse the cord. Never use the cord for carrying, pulling or unplugging the power tool. Keep cord away from heat, oil, sharp edges or moving parts. Damaged or entangled cords increase the risk of electric shock.

e) When operating a power tool outdoors, use an extension cord suitable for outdoor use. Use of a cord suitable for outdoor use reduces the risk of electric shock.

f) If operating a power tool in a damp location is unavoidable, use a residual current device (RCD) protected supply. Use of an RCD reduces the risk of electric shock.

3. Personal safety

a) Stay alert, watch what you are doing and use common sense when operating a power tool. Do not use a power tool while you are tired or under the influence of drugs, alcohol or medication. A moment of inattention while operating power tools may result in serious personal injury.

b) Use personal protective equipment. Always wear eye protection. Protective equipment such as dust mask, non-skid safety shoes, hard hat, or hearing protection used for appropriate conditions will reduce personal injuries.

c) Prevent unintentional starting. Ensure the switch is in the off position before connecting to power source and/or battery pack, picking up or carrying the tool. Carrying power tools with your finger on the switch or energising power tools that have the switch on invites accidents.

d) Remove any adjusting key or wrench before turning the power tool on. A wrench or a key left attached to a rotating part of the power tool may result in personal injury.

GENERAL POWER TOOL SAFETY WARNINGS

e) Do not overreach. Keep proper footing and balance at all times. This enables better control of the power tool in unexpected situations.

f) Dress properly. Do not wear loose clothing or jewellery. Keep your hair, clothing and gloves away from moving parts. Loose clothes, jewellery or long hair can be caught in moving parts.

g) If devices are provided for the connection of dust extraction and collection facilities, ensure these are connected and properly used. Use of dust collection can reduce dust-related hazards.

4. Power tool use and care

a) Do not force the power tool. Use the correct power tool for your application. The correct power tool will do the job better and safer at the rate for which it was designed.

b) Do not use the power tool if the switch does not turn it on and off. Any power tool that cannot be controlled with the switch is dangerous and must be repaired.

c) Disconnect the plug from the power source and/or the battery pack from the power tool before making any adjustments, changing accessories, or storing power tools. Such preventive safety measures reduce the risk of starting the power tool accidentally.

d) Store idle power tools out of the reach of children and do not allow persons unfamiliar with the power tool or these instructions to operate the power tool. Power tools are dangerous in the hands of untrained users.

e) Maintain power tools. Check for misalignment or binding of moving parts, breakage of parts and any other condition that may affect the power tool's operation. If damaged, have the power tool repaired before use. Many accidents are caused by poorly maintained power tools.

f) Keep cutting tools sharp and clean. Properly maintained cutting tools with sharp cutting edges are less likely to bind and are easier to control.

g) Use the power tool, accessories and tool bits etc. in accordance with these instructions, taking into account the working conditions and the work to be performed. Use of the power tool for operations different from those intended could result in a hazardous situation.

5. Service

a) Have your power tool serviced by a qualified repair person using only identical replacement parts. This will ensure that the safety of the power tool is maintained.

b) If the replacement of the supply cord is necessary, this has to be done by the manufacturer or its agent in order to avoid a safety hazard.

6. Additional Safety and Working Instructions

6.1 Dusts from materials such as lead-containing coatings, some wood types, minerals and metals can be harmful to one's health and cause allergic reactions, leading to respiratory infections and/or cancer. Materials containing asbestos may only be worked by specialists. Observe the relevant regulations in your country for the materials to be worked.

GENERAL POWER TOOL SAFETY WARNINGS

6.2 Prevent dust accumulation at the workplace. Dusts can easily ignite.

7 Additional Warnings for Sanders

7.1 Harmful/toxic dusts will arise from sanding e.g. lead painted surfaces, woods and metals.

Contact with or inhalation of these dusts can endanger the health of operator and bystanders.

Always use eye glasses and dust mask.

7.2 Hearing protection should be worn when using the sander.

7.3 Always wear safety glasses or eye shields when using the sander. Everyday eyeglasses have only impact-resistant lenses; they are not safety glasses. Following this rule will reduce the risk of serious personal injury.

7.4 Remove the plug from the socket before carrying out any adjustment, servicing or maintenance.

7.5 Fully unwind cable drum extensions to avoid potential overheating.

8.6 When an extension cable is required you must ensure it has the correct ampere rating for your power tool and is in a safe electrical condition.

7.7 Ensure your mains supply voltage is same as indicated on the rating plate.

7.8 Your tool is double insulated for additional protection against a possible electrical insulation failure within the tool.

7.9 Always check walls, floors and ceilings to avoid hidden power cables and pipes.

7.10. After long working period's external metal parts and accessories could be hot.

7.11 If possible, ensure the work-piece is firmly clamped to prevent movement.

7.12 Your sander is a hand held tool, do not clamp your sander.

7.13 Before sanding, check the area is free of nails, screws, etc.

7.14 Never stop the sander by applying a force to the base plate.

7.15 Only use paper in good condition. Do not use torn or worn paper.

8.16 Do not sand material containing asbestos due to a health risk.

7.17 Do not sand lead based paint due to the risk of lead poisoning.

7.18 Do not eat or drink in the working area of the sander.

7.19 Do not allow people to enter the working area without wearing a dust mask.

7.20 Where possible, seal off the working area to contain the dust for later removal.

7.21 Your tool is designed for dry sanding only, not wet sanding.

7.22 Your tool is designed for general purpose light polishing of wood and metals.

7.23 Do not sand magnesium material due to the risk of fire.

8. Using an Extension Cable.

8.1. If an extension cable is required, use an approved triple core extension cable suitable for the power input of the tool.

8.2. Grounded tools always require a three wire extension cable.

8.3. As the distance from the supply outlet increases you must use a heavier gauge extension cable. Using extension cables with inadequately sized wire causes a serious drop in voltage, resulting in loss of power and possible tool damage.

8.4. The smaller the gauge number of the wire the greater the capacity of the cord.

8.5. When using a cable reel, always unwind the cable completely.

SYMBOLS AND POWER RATING CHART



Danger! – Read the operating instructions to reduce the risk of injury.



Caution! Wear safety goggles.



Caution! Wear ear defenders. The impact of noise can cause damage to hearing.



Caution! Risk of Injury! Do not reach into the running saw blade.



Caution! Wear a dust mask.

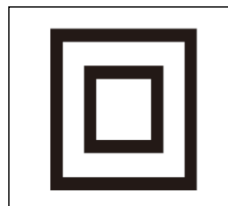

Class II Double Insulated

Amperes	7.5M	15M	25M	30M	45M	60M
0 – 2.0	6	6	6	6	6	6
2.1 – 3.4	6	6	6	6	6	6
3.5 - 5.0	6	6	6	6	10	15
5.1 – 7.1	10	10	10	10	15	15
7.1 – 12.0	15	15	15	15	20	20
12.1 – 20.0	20	20	20	20	25	-

MACHINE DETAILS AND PRODUCT FEATURES

Machine Details

Specifications:	PR12	PR14
Mains Voltage -	230V / 50Hz	
Power Consumption -	1800W	1200W
No Load Speed –	22000rpm	30000rpm
Speed Range -	6000-22000rpm	11000-30000rpm
Speed Presets -	7	7
Plunge Depth -	50mm	55mm
Sound Pressure Level L_{pA} -	96dB(A)	88dB(A)
Sound Pressure Level L_{WA} -	107dB(A)	98dB(A)
Gross Weight -	5.5kg	4.5kg
Nett Weight -	5.0kg	4.0kg

Package Contents:

Plunge Router (either PR12 or PR14)

Parallel Side-Fence

2 x Guide Rods

1/4" Collet (PR14 Only)

1/4" & 1/2" Collet (PR12 Only)

Dust Extraction Port

Guide Bush (18mm) (PR12)

Guide Bush (16mm) (PR14)

Routing Compass Point

Bit Change Tool

Chip Shield

MACHINE DETAILS AND PRODUCT FEATURES

Intended Use

The Machine is intended for routing grooves, edges, profiles and elongated holes as well as for copy routing in wood, plastics and light building materials, whilst resting firmly on the workpiece. With reduced speed and the appropriate routing bits, non-ferrous alloys can also be machined.

Use of this machine in any other way makes the manufacturer or seller not liable for any damages incurred in this use.

Product Features

1. Handle
2. Lock Button For I/O Switch
3. Speed Preset Thumbwheel
4. Spindle Lock
5. Guide Rod Locks
6. Chip Shield
7. Base Plate
8. Step Buffer
9. Depth Stop
10. Depth Stop Lock
11. Depth Stop Fine Adjustment
12. Plunge Locking Lever
13. Collet with Nut

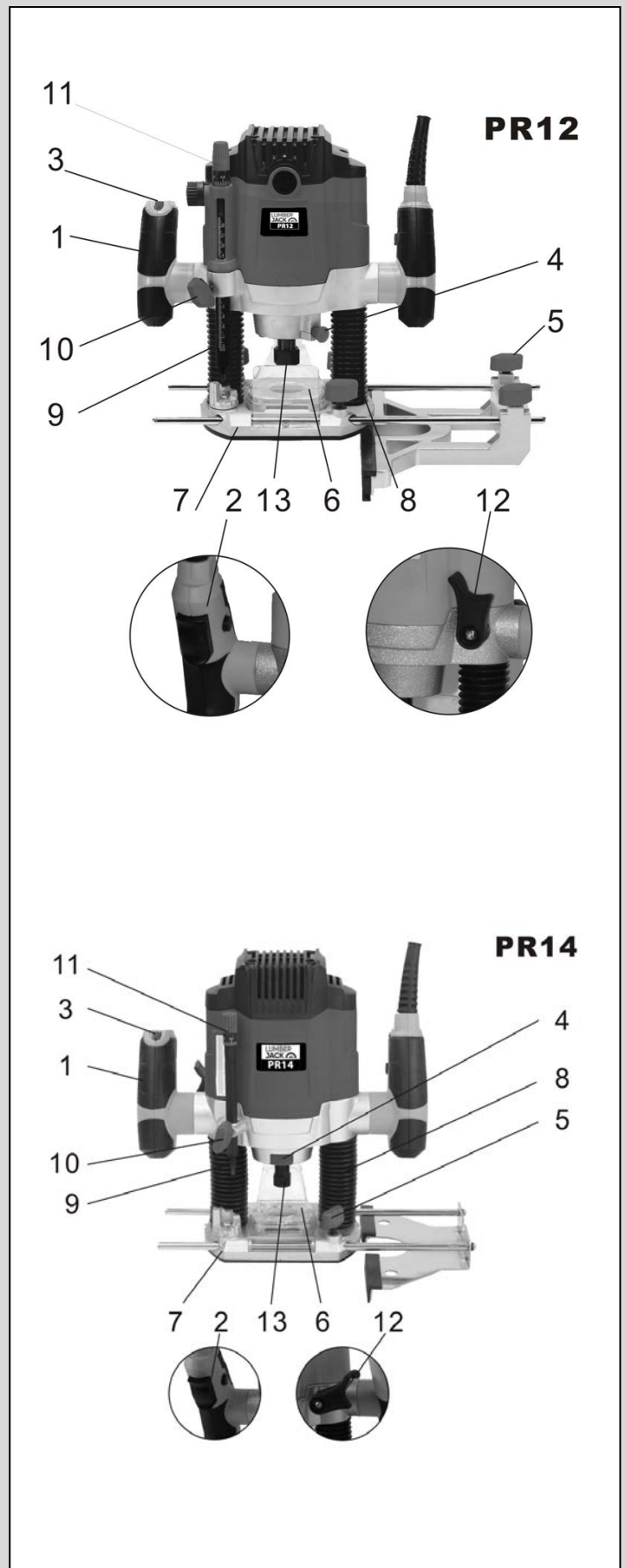

ASSEMBLY INSTRUCTIONS

Assembly

Avoid unintentional starting of the machine. During assembly and for all work on the machine, the power plug must not be connected to the mains supply.

Carefully remove all parts included in the delivery from their packaging.

Remove all packaging material from the machine and the accessories provided.

Before starting the operation of the machine for the first time, check if all parts listed in the box content section have been supplied

Note: Check the power tool for possible damage. Before further use of the machine, check that all protective devices are fully functional. Any lightly damaged parts must be carefully checked to ensure flawless operation of the tool. All parts must be properly mounted and all conditions fulfilled that ensure faultless operation.

Damaged protective devices and parts must be immediately replaced by an authorised service centre.

Warning – Do not tighten the collet without a cutter fitted.

Warning – Always use cutters with shanks that match the diameter of the collet.

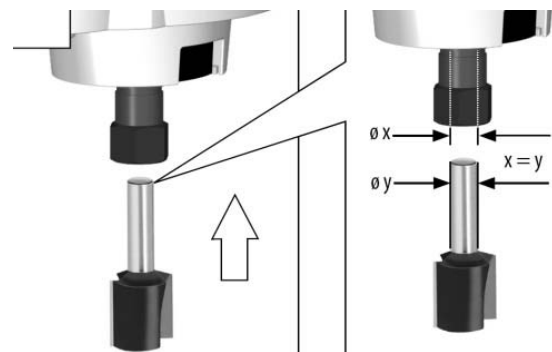

Caution – Please take extra care when fitting or removing a cutter to avoid cuts.

Fitting and Removing a Cutter

Fitting Cutters–

- Loosen the Collet nut using the tool provided.

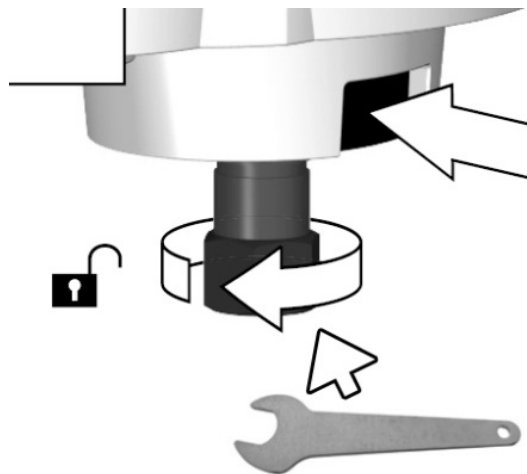

- Insert the cutter into the collet as far as it can go then pull the cutter back out 1-2mm. (this is to stop any hammer action that can damage the router.) Also be sure that there is at least 4mm from the nut to the cutting edge

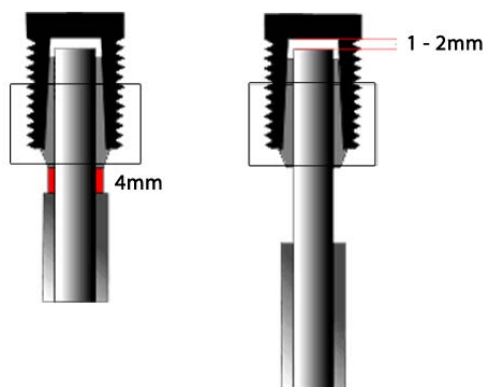

- Press the spindle lock (4) and rotate the spindle until the router spindle is locked (you may need to turn the spindle slightly to engage it).

ASSEMBLY INSTRUCTIONS

- Tighten the collet nut with the tool provided. Do not use excessive force.

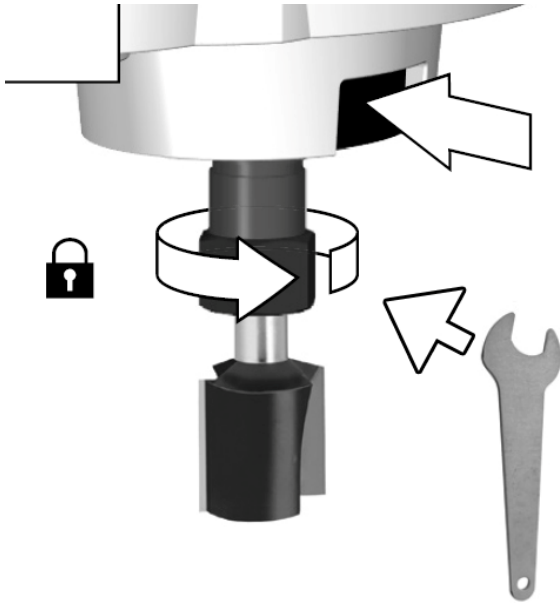

Removing Cutters

- Engage the spindle lock (4) and undo the collet nut with the tool provided.
- The cutter should now slide out.
- Each time you finish using a cutter, remove it and store it in a safe place.

Adjusting the Depth of Cut

- Place the machine with cutter fitted on to the workpiece.
- Undo the depth stop lock (10) for securing the depth stop (9).
- Lift up the plunge locking lever (12) to unlock the plunge feature.
- Lower the machine slowly until the cutter touches the workpiece and secure it with the plunge locking lever (12).

- Set the depth stop (9) to zero as shown below. To achieve this spin the step buffer (8) to its highest setting that allows the depth stop (9) to be set to zero then rotate the Depth stop fine adjustment knob (11) until it touches the step buffer (8) (This can be rotated giving steps of 3mm.).

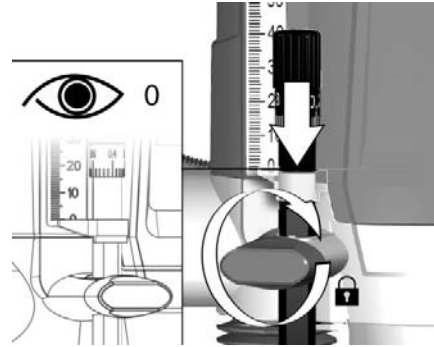

- Now untighten the depth stop lock (10) and using the scale on the router set the depth stop (9) to the required depth, and re-tighten the depth stop lock (10).

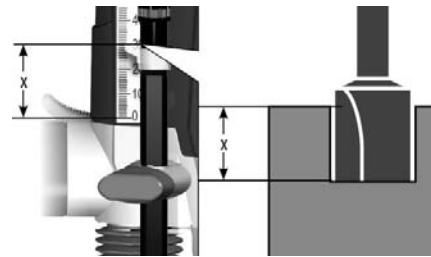

Please note – this operation need to be performed whenever a new cutter is installed.

Parallel Side-Fence Assembly

- Assemble as shown below



ASSEMBLY INSTRUCTIONS

Dust Extraction Port Fitting

- Insert Dust extractor port as shown



- Screw in place the dust port from underneath
- Insert a 35mm diameter extraction hose.



- Make sure the dust extraction is turned on before the router is.

Guide Bush Fitting

- The dust port needs to be inserted to provide the “nut” for the screws, assemble as shown

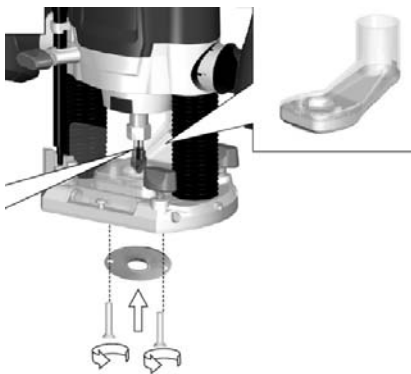

Mounting the Chip Shield

- Simply slot the chip shield in or out of its housing on the base plate.

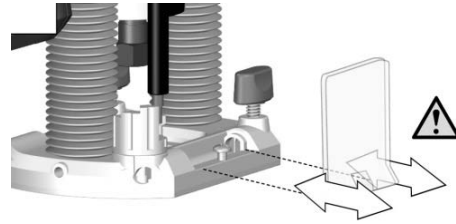

Mounting the Routing Compass

- Remove one of the bars from the parallel side-fence and fit the routing compass attachment as shown below.

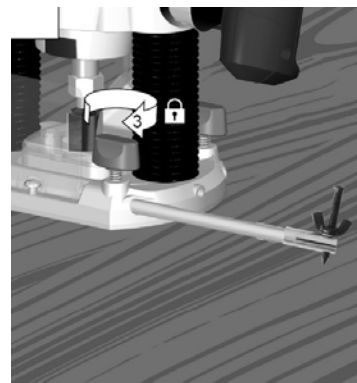
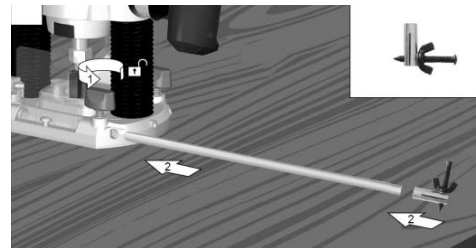

OPERATION

Operation

Starting and Stopping

START

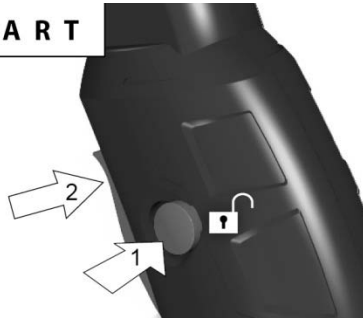

STOP



Speed Settings

- To adjust the speed of the router simply adjust with the thumb wheel



Routing Direction

- When routing along an edge, the direction of the router travel should be against that of the rotation of the cutter. This will create the correct cutting action and prevent the cutter 'snatching'. It will also pull the router towards the workpiece and hence the side-fence or guide bearing will be less likely to wander from the edge of the workpiece.

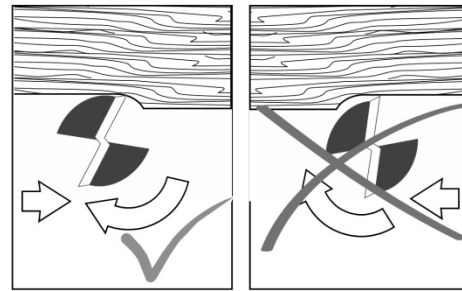

Feed Speed

- The speed at which the cutter is fed into the wood must not be too fast that the motor slows down, or too slow that the cutter leaves burn marks on the face of the wood. Practice judging the speed by listening to the sound of the motor when routing.

Routing with the Parallel Side-Fence

- Make sure the guide rod locks (5) are fully released. Slide the guide rods into the routing base plate (7) and tighten the guide rod locks (5).
- Adjust the side-fence to the required distance and clamp in place with the guide rod locks (5).
- Set the cutter and depth as mentioned previously in this manual.
- Switch on the router and when the cutter reaches full speed, release the plunge lock lever (12) and then gently lower the cutter into the workpiece and lock the plunge.
- Feed along the timber, keeping sideways pressure to ensure the side fence does not wander away from the workpiece edge and downward pressure on the inside hand to prevent the router from tipping.
- When finished, raise the router, secure with the plunge locking lever (12) and switch off.

OPERATION





Routing with the Compass

- Set up the Compass as previously mentioned in this manual.
- Place the machine on the workpiece and ensure pin on compass will pierce the workpiece surface.
- Measure the radius and fix the point of the compass in position.
- Fasten the compass rod in the routing base (7) with the guide rod locks (5).
- Set the cutting depth as mentioned previously in this manual.
- Switch on the machine.
- After releasing the plunge locking lever (12), lower the machine slowly as far as the depth stop and lock it there.

- Cut grooves, rebates etc. at a steady rate of feed, in an anti-clockwise direction.
- When finished, release plunge locking lever (12) to raise the machine.
- Switch off the machine and re lock the plunge locking lever.

Speed Guide

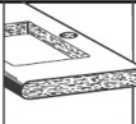
Here is a rough guide to the speed needed for certain applications -

		 soft wood	 hard wood	 plastics	 aluminium
3-6 mm	HSS	23000 min ⁻¹	20400 min ⁻¹	15200 min ⁻¹	15200 min ⁻¹
6-8 mm	HSS	20400 min ⁻¹	17800 min ⁻¹	15200 min ⁻¹	12600 min ⁻¹
8-10 mm	HM	17800 min ⁻¹	15200 min ⁻¹	12600 min ⁻¹	10000 min ⁻¹
10-12 mm	HM	17800 min ⁻¹	12600 min ⁻¹	10000 min ⁻¹	10000 min ⁻¹
12-20 mm	HM	15200 min ⁻¹	12600 min ⁻¹	10000 min ⁻¹	10000 min ⁻¹
20-25 mm	HM	15200 min ⁻¹	12600 min ⁻¹	10000 min ⁻¹	10000 min ⁻¹
25-40 mm	HM	15200 min ⁻¹	12600 min ⁻¹	10000 min ⁻¹	10000 min ⁻¹

Maintenance and Service And LUMBERJACK GUARANTEE

Before any work on the machine itself, ensure the mains plug has been removed for the socket.

For safe and proper working of the tool, always keep the machine and any ventilation slots clear and clean from any dust or contaminants.

Cleaning

- Keep the machine clean at all times. Some maintenance products and solvents may damage the plastic parts; these include products containing Benzene, Trichloroacetyl Chloride and Ammonia.

- Never use any caustic agents to clean the plastic parts.

1. Guarantee

1.1 Lumberjack guarantees that for a period of 12 months from the date of purchase the components of qualifying products (see clauses 1.2.1 to 1.2.8) will be free from defects caused by faulty construction or manufacture.

1.2. During this period Lumberjack, will repair or replace free of charge any parts which are proved to be faulty in accordance with paragraph 1.1 providing that:

1.2.1 You follow the claims procedure set out in clause 2

1.2.2 Lumberjack and its authorised dealers are given reasonable opportunity after receiving notice of the claim to examine the product

1.2.3 If asked to do so by Lumberjack or its Authorised dealer, you return the product at your own cost to Lumberjack's or supplying Authorised Dealer's premises, for the examination to take place clearly stating the Returns Material Authorisation number given by Lumberjack or an Authorised Dealer.

1.2.4 The fault in question is not caused by industrial use, accidental damage, fair wear and tear, wilful damage, neglect, incorrect electrical connection, misuse, or alteration or repair of the product without approval.

1.2.5 The product has been used in a domestic environment only

1.2.6 The fault does not relate to consumable items such as blades, bearings, drive belts, or other wearing parts which can reasonably be expected to wear at different rates depending on usage.

LUMBERJACK GUARANTEE

1.2.7 The product has not been used for hire purposes.

1.2.8 The product has been purchased by you as the guarantee is not transferable from a private sale.

2. Claims Procedure

2.1 In the first instance please contact the Authorised Dealer who supplied the product to you. In our experience many initial problems with machines that are thought to be faulty due to faulty parts are actually solved by correct setting up or adjustment of the machine. A good Authorised Dealer should be able to resolve the majority of these issues much more quickly than processing a claim under the guarantee. If a return is requested by the Authorised Dealer or Lumberjack, you will be provided with a Returns Material Authorisation number which must be clearly stated on the returned package, and any accompanying correspondence. Failure to provide a Returns Material Authorisation number may result in item being refused delivery at Authorised Dealer.

2.2 Any issues with the product resulting in a potential claim under the guarantee must be reported to the Authorised Dealer from which it was purchased within 48 hours of Receipt.

2.3 If the Authorised Dealer who supplied the product to you has been unable to satisfy your query, any claims made under this Guarantee should be made directly to Lumberjack. The Claim itself should be made in a letter setting out the date and place of purchase, giving a brief explanation of the problem which has led to the claim. This letter should be then sent with proof

of purchase to Lumberjack. If you include a contact number with this it will speed your claim up.

2.4 Please note that it is essential that the letter of claim reaches Lumberjack on the last day of this Guarantee at the latest. Late claims will not be considered.

3. Limitation of Liability

3.1 We only supply products for domestic and private use. You agree not to use the product for any commercial, business or resale purposes and we have no liability to you for any loss of profit, loss of business, business interruption or loss of business opportunity.

3.2 This Guarantee does not confer any rights other than these expressly set out above and does not cover any claims for consequential loss or damage. This Guarantee is offered as an extra benefit and does not affect your statutory rights as a consumer.

4. Notice

This Guarantee applies to all product purchased from an Authorised Dealer of Lumberjack within the United Kingdom. Terms of Guarantee may vary in other countries.

CE DECLARATION OF CONFORMITY

TOOLSAVE

Unit C, Manders Ind. Est.,
Old Heath Road, Wolverhampton,
WV1 2RP.
Tel: 01902 450 470

Declares that the 1/2" Plunge Router(PR12)

Is in compliance with the regulations included in the Directives:2006/42/EC

EC DECLARATION OF CONFORMITY

Certificate for EC-type examination delivered by Interk Testing Services Hangzhou 16
No. 1 Ave., Xiasha Economic Development District, Hangzhou 310018, China
(Verification No.:HZ11080122-V1)

Person who declares: Bill Evans

CE

01.06.2020

The Director



Parts List(PR12)

No.	Description	No.	Description
1	Screw ST4.2×16	31	Base
2	Top cover	32	Dust ejector B
3	Speed stabilized module	33	Dust ejector A
4	Screw ST2.9×10	34	Hex nut M4
5	House	35	Left handle cover
6	Brush holder	36	Screw ST4.2×13
7	Carbon brush	37	Speed regulator
8	Brush holder cap	38	Wire shield B
9	Logo plate	39	Screw M5×16
10	Data plate	40	Spring washer 5
11	Ruler knob	41	Plain washer 5
12	Stator	42	Left handle
13	Screw ST3.5×13	43	Ruler locking knob
14	Wind baffle	44	Ruler bush
15	Flexible sleeve	45	Pipe circlip
16	Spring	46	Twist spring
17	Guide pipe	47	Locking screw
18	Locking knob 1	48	Locking knob
19	Knob spring	49	Plain washer 4
20	Steel ball SΦ5.5	50	Spring washer 4
21	Spring	51	Screw M4×10
22	Hex socket set screw M6×16	52	Ruler
23	Screw M6×16	53	Static ajuster
24	Steel bush	54	Ruler spring
25	Depth stop	55	Dynamic ajuster
26	Base plate	56	Bearing 629
27	Countersunk screw M4×10	57	Induction ring
28	Screw M4×30	58	Rotor
29	Transparent baffle	59	Rotor locating nut
30	Screw M4×8	60	Collet spring

Parts List(PR12)

No.	Description	No.	Description
61	Collet	75	Gear box
62	Collet nut	76	Fore cover
63	Bearing plate	77	Plain washer 6
64	Bearing 6004	78	Screw M6×16
65	Right handle	79	Guide rack
66	Wire shield A	80	Rack pad
67	Switch	81	Screw M6×12
68	Cable	82	Guiding rod
69	Cable jacket	83	Template guide
70	Cable clamp	84	Spanner
71	Right handle cover	85	Centring pin
72	Capacitor 0.33 μ F	86	Copy follower
73	Spindle lock	87	Knob spring
74	Spring	88	Screw M4×70

Parts Diagram(PR12)

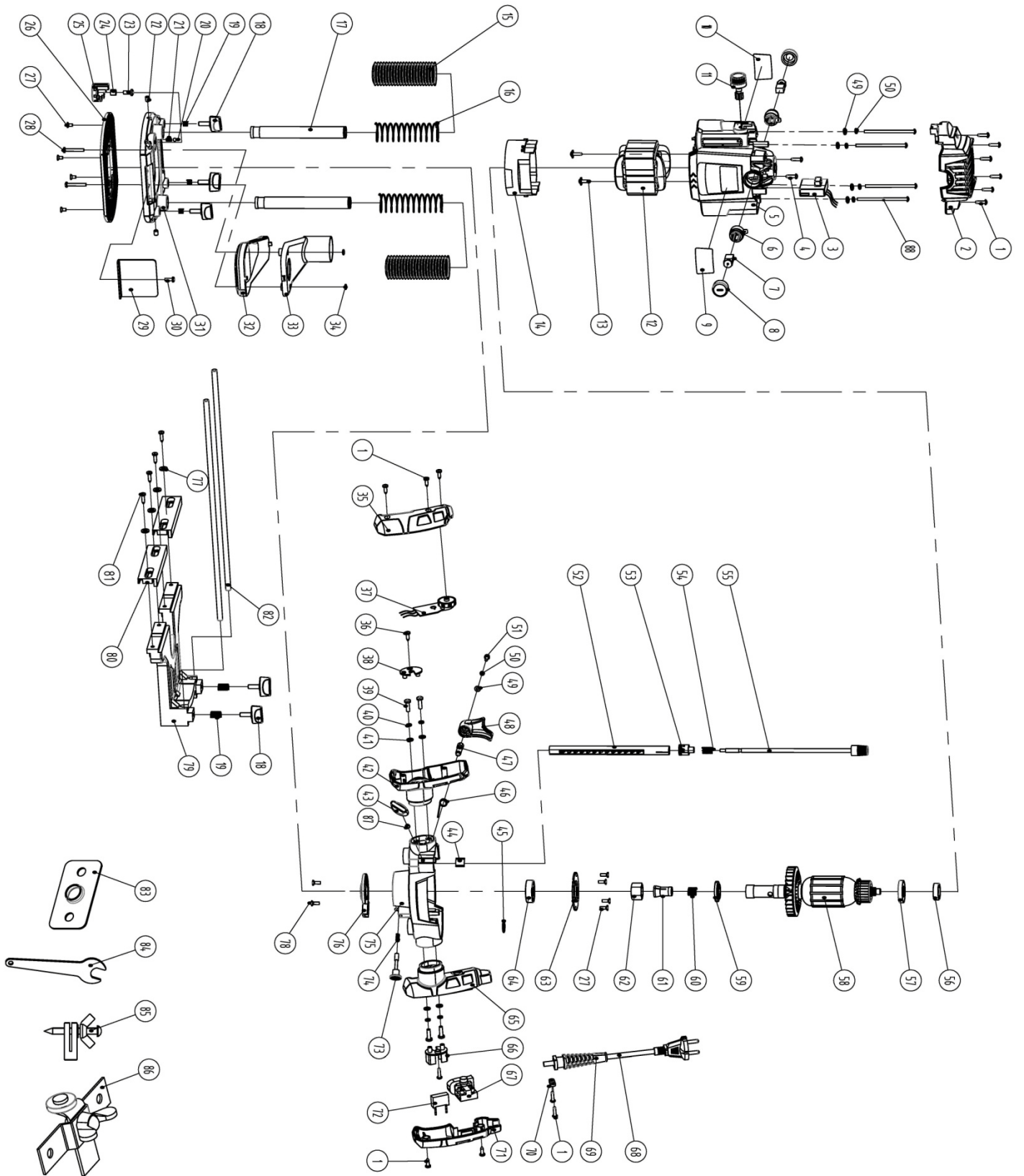

CE DECLARATION OF CONFORMITY

TOOLSAVE

Unit C, Manders Ind. Est.,
Old Heath Road, Wolverhampton,
WV1 2RP.
Tel: 01902 450 470

Declares that the 1/4" Plunge Router(PR14)

Is in compliance with the regulations included in the Directives:2006/42/EC

EC DECLARATION OF CONFORMITY

Certificate for EC-type examination delivered by Interk Testing Services Hangzhou 16
No. 1 Ave., Xiasha Economic Development District, Hangzhou 310018, China
(Verification No.: 150800324HZH-V1)

Person who declares: Bill Evans

CE

01.06.2020

The Director



Parts List(PR14)

No.	Description	No.	Description
1	Cable	31	Washer
2	Cable jacket	32	Knob spring
3	Tapping screw ST4.2×16	33	Knob
4	Right handle cover	34	Left handle
5	Capacitor 0.33 μ F	35	Board B
6	Tapping screw ST4.2×13	36	Left handle cover
7	Screw M5×16	37	Tapping screw ST4.2×60
8	Spring washer 4	38	Stator
9	Washer 4	39	Depth label
10	Board A	40	Trademark
11	Right handle	41	Housing case
12	Tapping screw ST4.2×22	42	Cover plate
13	Switch	43	Tapping screw ST2.9×9.5
14	Cable clip	44	Brush holder cover
15	Gear box	45	Carbon brush
16	Bearing 6003-2Z	46	Upper cover
17	Platen	47	Brush holder bush
18	Screw M4×10	48	Nameplate
19	Rotor	49	Wind baffle
20	Bearing 608-2Z	50	Nut
21	Still adjust	51	Self lock spring
22	Ruler spring	52	Front cover
23	Moving adjust	53	Self lock piece
24	Pointing piece	54	Self lock Knob
25	Ruler	55	Collet spring
26	Screw M4×10	56	Collet 8
27	Control board	57	Collet nut
28	Plastic spanner	58	Guide pole A
29	Screw	59	Screw M6×16
30	Spring	60	Iron sleeve

Parts List(PR14)

No.	Description	No.	Description
61	Resist piece	77	Screw
62	Steel ball $\Phi 5.5$	78	Knob 1
63	Resist piece spring	79	Screw M4 \times 6
64	Up and down spring	80	Guide rod
65	Plastic loop	81	Plastic board
66	Guide pole A	82	Ruler
67	Circlip for shaft 15	83	Washer 5
68	Nut M5	84	Spring washer 5
69	Plastic cover A	85	Screw M5 \times 10
70	Plastic cover B	86	Collet 6
71	Base	87	Localizer
72	Locking screw M5 \times 10	88	Spanner
73	Screw M5 \times 25	89	Propriety
74	Base plate	90	Knob spring
75	Baffle		

Parts Diagram(PR14)

