



SAFETY AND OPERATING MANUAL

Random Orbital Palm Sander OS125



ORIGINAL INSTRUCTIONS



OS125

TABLE OF CONTENTS

Welcome to Lumberjack!

Dear customer, Congratulations on your purchase. Before using the product for the first time please be sure to read these instructions for use.

They provide you with all information necessary for using the product safely and to ensure its long service life.

Closely observe all safety information in these instructions!

General Power Tool Safety Warnings.....	01
Symbols & Cable Rating Chart	04
Machine Details and Product Features.....	05
Assembly.....	06
Operation.....	08
Maintenance and Service.....	09
Lumberjack Guarantee.....	11
Declaration of Conformity.....	13
Parts List.....	14
Parts Diagram.....	15



OS125

GENERAL POWER TOOL SAFETY WARNINGS

WARNING Read all safety warnings and all instructions. Failure to follow the warnings and instructions may result in electric shock, fire and/or serious injury.

Save all warnings and instructions for future reference. The term "power tool" in the warnings refers to your electric (corded) power tool or battery-operated (cordless) power tool.

1. Work area safety

a) Keep work area clean and well lit. Cluttered or dark areas invite accidents.

b) Do not operate power tools in explosive atmospheres, such as in the presence of flammable liquids, gases or dust. Power tools create sparks which may ignite the dust or fumes.

c) Keep children and bystanders away while operating a power tool. Distractions can cause you to lose control.

2. Electrical safety

a) Power tool plugs must match the outlet. Never modify the plug in any way. Do not use any adapter plugs with grounded power tools. Unmodified plugs and matching outlets will reduce risk of electric shock.

b) Avoid body contact with grounded surfaces, such as pipes, radiators, ranges and refrigerators. There is an increased risk of electric shock if your body is grounded.

c) Do not expose power tools to rain or wet conditions. Water entering a power tool will increase the risk of electric shock.

d) Do not abuse the cord. Never use the cord for carrying, pulling or unplugging the power tool. Keep cord away from heat, oil, sharp edges or moving parts. Damaged or entangled cords increase the risk of electric shock.

e) When operating a power tool outdoors, use an extension cord suitable for outdoor use. Use of a cord suitable for outdoor use reduces the risk of electric shock.

f) If operating a power tool in a damp location is unavoidable, use a residual current device (RCD) protected supply. Use of an RCD reduces the risk of electric shock.

3. Personal safety

a) Stay alert, watch what you are doing and use common sense when operating a power tool. Do not use a power tool while you are tired or under the influence of drugs, alcohol or medication. A moment of inattention while operating power tools may result in serious personal injury.

b) Use personal protective equipment. Always wear eye protection. Protective equipment such as dust mask, non-skid safety shoes, hard hat, or hearing protection used for appropriate conditions will reduce personal injuries.

c) Prevent unintentional starting. Ensure the switch is in the off position before connecting to power source and/or battery pack, picking up or carrying the tool. Carrying power tools with your finger on the switch or energising power tools that have the switch on invites accidents.

d) Remove any adjusting key or wrench before turning the power tool on. A wrench or a key left attached to a rotating part of the power tool may result in personal injury.

GENERAL POWER TOOL SAFETY WARNINGS

e) Do not overreach. Keep proper footing and balance at all times. This enables better control of the power tool in unexpected situations.

f) Dress properly. Do not wear loose clothing or jewellery. Keep your hair, clothing and gloves away from moving parts. Loose clothes, jewellery or long hair can be caught in moving parts.

g) If devices are provided for the connection of dust extraction and collection facilities, ensure these are connected and properly used. Use of dust collection can reduce dust-related hazards.

4. Power tool use and care

a) Do not force the power tool. Use the correct power tool for your application. The correct power tool will do the job better and safer at the rate for which it was designed.

b) Do not use the power tool if the switch does not turn it on and off. Any power tool that cannot be controlled with the switch is dangerous and must be repaired.

c) Disconnect the plug from the power source and/or the battery pack from the power tool before making any adjustments, changing accessories, or storing power tools. Such preventive safety measures reduce the risk of starting the power tool accidentally.

d) Store idle power tools out of the reach of children and do not allow persons unfamiliar with the power tool or these instructions to operate the power tool. Power tools are dangerous in the hands of untrained users.

e) Maintain power tools. Check for misalignment or binding of moving parts, breakage of parts and any other condition that may affect the power tool's operation. If damaged, have the power tool repaired before use. Many accidents are caused by poorly maintained power tools.

f) Keep cutting tools sharp and clean. Properly maintained cutting tools with sharp cutting edges are less likely to bind and are easier to control.

g) Use the power tool, accessories and tool bits etc. in accordance with these instructions, taking into account the working conditions and the work to be performed. Use of the power tool for operations different from those intended could result in a hazardous situation.

5. Service

a) Have your power tool serviced by a qualified repair person using only identical replacement parts. This will ensure that the safety of the power tool is maintained.

b) If the replacement of the supply cord is necessary, this has to be done by the manufacturer or its agent in order to avoid a safety hazard.

6. Additional Safety and Working Instructions

6.1 Dusts from materials such as lead-containing coatings, some wood types, minerals and metals can be harmful to one's health and cause allergic reactions, leading to respiratory infections and/or cancer. Materials containing asbestos may only be worked by specialists. Observe the relevant regulations in your country for the materials to be worked.

GENERAL POWER TOOL SAFETY WARNINGS

6.2 Prevent dust accumulation at the workplace. Dusts can easily ignite.

7 Additional Warnings for Sanders

7.1 Harmful/toxic dusts will arise from sanding e.g. lead painted surfaces, woods and metals.

Contact with or inhalation of these dusts can endanger the health of operator and bystanders.

Always use eye glasses and dust mask.

7.2 Hearing protection should be worn when using the sander.

7.3 Always wear safety glasses or eye shields when using the sander. Everyday eyeglasses have only impact-resistant lenses; they are not safety glasses. Following this rule will reduce the risk of serious personal injury.

7.4 Remove the plug from the socket before carrying out any adjustment, servicing or maintenance.

7.5 Fully unwind cable drum extensions to avoid potential overheating.

8.6 When an extension cable is required you must ensure it has the correct ampere rating for your power tool and is in a safe electrical condition.

7.7 Ensure your mains supply voltage is same as indicated on the rating plate.

7.8 Your tool is double insulated for additional protection against a possible electrical insulation failure within the tool.

7.9 Always check walls, floors and ceilings to avoid hidden power cables and pipes.

7.10. After long working period's external metal parts and accessories could be hot.

7.11 If possible, ensure the work-piece is firmly clamped to prevent movement.

7.12 Your sander is a hand held tool, do not clamp your sander.

7.13 Before sanding, check the area is free of nails, screws, etc.

7.14 Never stop the sander by applying a force to the base plate.

7.15 Only use paper in good condition. Do not use torn or worn paper.

8.16 Do not sand material containing asbestos due to a health risk.

7.17 Do not sand lead based paint due to the risk of lead poisoning.

7.18 Do not eat or drink in the working area of the sander.

7.19 Do not allow people to enter the working area without wearing a dust mask.

7.20 Where possible, seal off the working area to contain the dust for later removal.

7.21 Your tool is designed for dry sanding only, not wet sanding.

7.22 Your tool is designed for general purpose light polishing of wood and metals.

7.23 Do not sand magnesium material due to the risk of fire.

8. Using an Extension Cable.

8.1. If an extension cable is required, use an approved triple core extension cable suitable for the power input of the tool.

8.2. Grounded tools always require a three wire extension cable.

8.3. As the distance from the supply outlet increases you must use a heavier gauge extension cable. Using extension cables with inadequately sized wire causes a serious drop in voltage, resulting in loss of power and possible tool damage.

8.4. The smaller the gauge number of the wire the greater the capacity of the cord.

8.5. When using a cable reel, always unwind the cable completely.

SYMBOLS AND POWER RATING CHART



Danger! – Read the operating instructions to reduce the risk of injury.



Caution! Wear safety goggles.



Caution! Wear ear defenders. The impact of noise can cause damage to hearing.



Caution! Risk of Injury! Do not reach into the running saw blade.



Caution! Wear a dust mask.

Amperes	7.5M	15M	25M	30M	45M	60M
0 – 2.0	6	6	6	6	6	6
2.1 – 3.4	6	6	6	6	6	6
3.5 - 5.0	6	6	6	6	10	15
5.1 – 7.1	10	10	10	10	15	15
7.1 – 12.0	15	15	15	15	20	20
12.1 – 20.0	20	20	20	20	25	-

MACHINE DETAILS AND PRODUCT FEATURES

Machine Details

Specifications:

Mains Voltage -	230V / 50Hz
Power Consumption -	350W
No load Speed-	0-13000rpm
Pad Size -	125mm

Package Contents:

Sander
Dust collection box

Intended Use

The machine has been designed for the use of sanding wood, plastics, metal and painted surfaces.

Product Features

1. Power cord
2. Dust collector
3. Sanding pad
4. ON/OFF Switch
5. Handle
6. Speed control

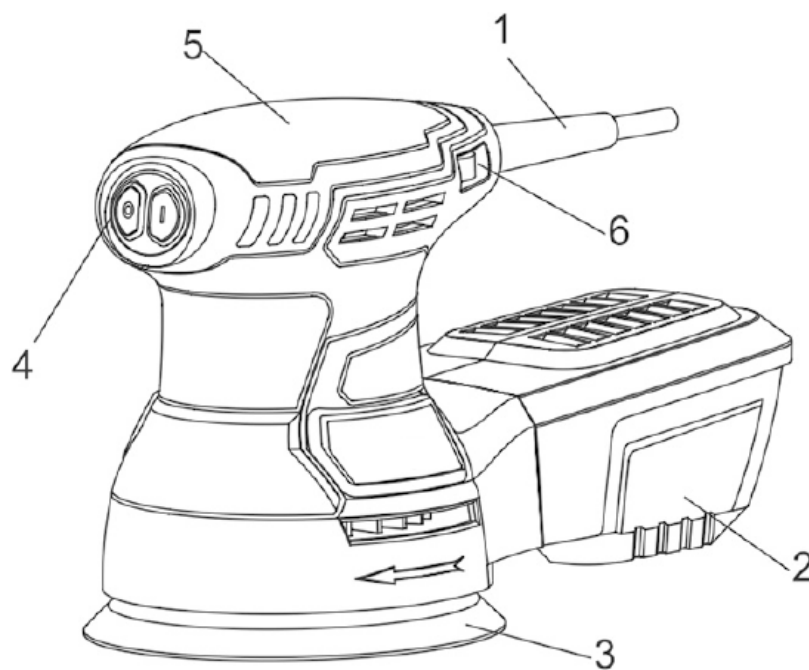
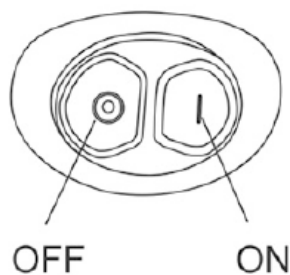

ASSEMBLY INSTRUCTIONS

Assembly

Avoid unintentional starting of the machine. During assembly and for all work on the machine, the power plug must not be connected to the mains supply.

Carefully remove all parts included in the delivery from their packaging.

Remove all packaging material from the machine and the accessories provided.

Before starting the operation of the machine for the first time, check if all parts listed in the box content section have been supplied

Note: Check the power tool for possible damage. Before further use of the machine, check that all protective devices are fully functional. Any lightly damaged parts must be carefully checked to ensure flawless operation of the tool. All parts must be properly mounted and all conditions fulfilled that ensure faultless operation.

Damaged protective devices and parts must be immediately replaced by an authorised service centre.

Dust Extraction

The sander can either be connected to the dust collector(supplied) or to an external dust extraction device or vacuum cleaner.

Dust collector

Proceed as follows to fit the dust collector to the machine:

- Insert the dust collector(A) into the slots in the dust extraction outlet(B) as shown.
- Pull the dust collector to remove it from the machine.

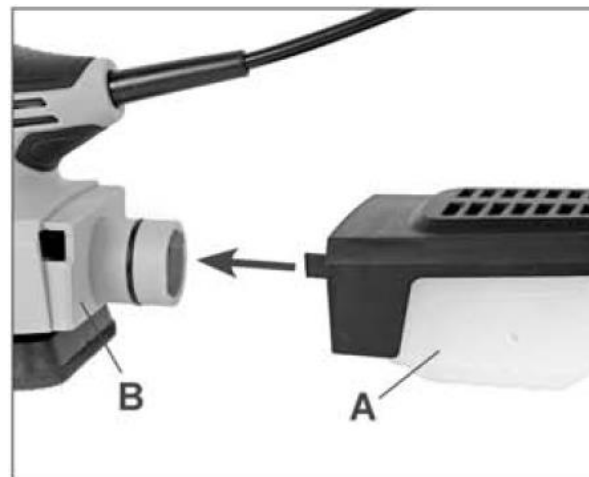

Changing/emptying the collection bag

- Remove the dust collector from the machine as described above. Remove the black cover (C) from the dust collector.
- Empty the dust collector and clean using compressed air. The dust collector can also be washed but must be dried thoroughly before being re-used.



Warning: Do not use the dust collector when sanding metal. The hot metal particles could cause any residual dust or

ASSEMBLY INSTRUCTIONS & OPERATION

the dust collector itself to catch fire.

Note: Empty the dust collector regularly and after each use.

Installing sanding paper

- Unplug your sander.

WARNING: Failure to unplug your sander could result in accidental starting causing possible serious personal injury.

- Your sander uses hook-and-loop backed sandpaper, which firmly grips the backing pad when applied with moderate pressure.

To change, peel off the old sandpaper, remove dust from the backing pad if necessary, and press the new sandpaper in place. Be sure to align the sanding sheet holes with the holes in the backing pad to allow the dust extraction system to function.

NOTE: Holes in sanding disc must line up with holes in the backing pad in order for the dustless feature of your sander to function properly.

Tips and instructions

- When sanding, it is important to start with a coarse sanding disc and to progress using finer sanding discs. If the sanding disc used is too coarse the surface finish will not be smooth, and could even become rougher. If the sanding disc used is too fine, poor results will be achieved.

- When possible during sanding keep the sanding plate/attachment parallel with the surface of the workpiece. Do not exert excessive pressure on the sander. Sanding discs which are covered in dust or residue produce poor results.

Note: Excessive pressure does not increase sanding performance!

- Use the right abrasive for your application. Bear in mind the properties of the workpiece and the result you wish to achieve.

- Sanding performance is determined largely by the choice of abrasive and properties of the material surface.

OPERATION

Operation

Switch ON/OFF

- Press the "I" button to turn the machine ON
- Press the "O" button to turn the machine OFF.

Adjust the speed

- Your sander is also equipped with a variable speed dial. The sander's orbital pad speed can be preset from zero to maximum nameplate OPM by rotating the dial in the housing. The dial may be set on or between any of six positions(1= low through Max=high). Flush sanding can be performed with your sander. The front edge of your sander allows flush sanding. Upon completion of sanding operation, turn sander off and wait until sanding disc comes to a complete.

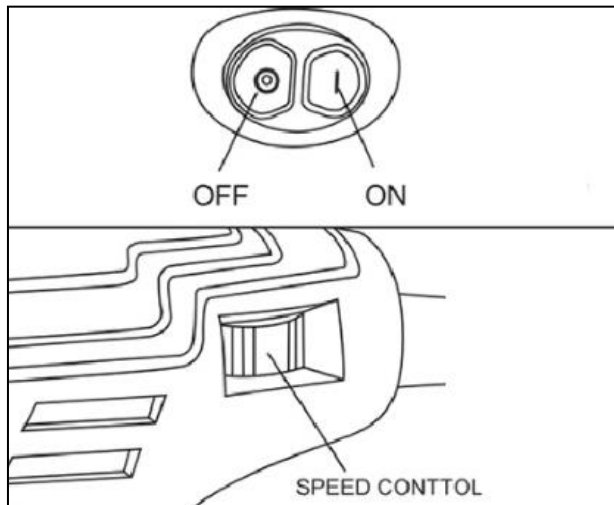

Using the sander

Caution: wear safety goggles, ear protection and a dust mask when using the machine.

Always keep a firm grip on the tool. Use both hands. Keep your fingers away from the sanding plate/attachment.

Switch the machine ON and wait until the machine has reached its full no load speed before engaging with the workpiece.

Apply the sanding plate/attachment gently to the workpiece. Exerting excessive pressure does not improve sanding performance and can lead to a shortened disc life and increased wear to the tool.

Excessive pressure does not increase sanding performance!

MAINTENANCE AND SERVICE

Maintenance and Service

Maintenance and Cleaning

Before any work on the dust collector itself, pull the mains plug.

For safe and proper working, always keep the dust collector and ventilation slots clean.

If the replacement of the supply cord is necessary, this has to be done by an authorized service agent in order to avoid a safety hazard.

If the dust collector should fail despite the care taken in manufacturing and testing procedures, repair should be carried out by an authorised service centre.

General inspection

Regularly check that all the screws are tight as they may vibrate and loosen over time.

Inspect the power cable(3) prior to each use for damage or wear.

Repairs should only be carried out by an qualified technician.

Keep your tool clean at all times. Dirt and dust will cause internal parts to wear quickly and shorten the tool's service life. Clean the body of the tool with a soft brush or dry cloth.

We recommend using compressed air when possible to clean down the sander. This aids the products longevity.

CAUTION: Never use caustic agents to clean plastic parts. If dry cleaning is not sufficient, using a mild detergent on a damp cloth is recommended.

WARNING! Do not allow the tool to come into contact with water or any other liquid. Ensure the tool is thoroughly dry before using it. If available, use clean, dry, compressed air to blow through the ventilation holes(where applicable).

Surfaces need to be clean, free of dirt and foreign matter(hair, sand etc.) and in good condition.

Cleaning dust box assembly

As previously mentioned, for more efficient operation, empty dust bag when no more than half full. This will permit the air to flow through the bag better.

WARNING: Collected sanding dust from sanding surface coatings such as polyurethanes, linseed oil, etc., can self ignite in your sander dust box or elsewhere and cause fire. To reduce the risk of fire always empty your dust box frequently(10-15minutes) while sanding and never store or leave a sander without totally emptying its dust box. Also follow the recommendations of the coatings manufacturers.

To empty dust box

- Unplug your sander.

WARNING: Failure to unplug your sander could result in accidental starting causing possible serious personal injury.

- Remove dust bag from sander and shake out dust.

MAINTENANCE AND SERVICE

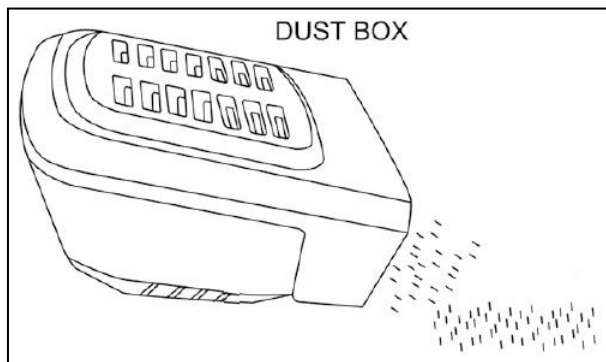

General

Avoid using solvents when cleaning plastic. Most plastics are susceptible to damage from various types of commercial solvents and may be damaged by their use. Use clean cloths to remove dirt, carbon dust, etc.

WARNING: Do not at any time let brake fluids, gasoline, petroleum-based products, penetration oils, etc. come in contact with plastic parts. They contain chemicals that can damage, weaken, or destroy plastic.

When electric tools are used on fibreglass boats, sports cars, wallboard, spackling compounds, or plaster, it has been found that they are subject to accelerated wear and bearings, brushes, commutators, etc. consequently, it is not recommended that this tool be used for extended work on any fibreglass material, wallboard, spackling compounds, or plaster. During any use on fibreglass it is extremely important that the tool is cleaned frequently by blowing with an air jet.

WARNING: Always wear safety goggles or safety glasses with side shields during power tool operation or when blowing dust. If operation is dusty, also wear a dust mask.

LUMBERJACK GUARANTEE

1. Guarantee

1.1 Lumberjack guarantees that for a period of 12 months from the date of purchase the components of qualifying products (see clauses 1.2.1 to 1.2.8) will be free from defects caused by faulty construction or manufacture.

1.2. During this period Lumberjack, will repair or replace free of charge any parts which are proved to be faulty in accordance with paragraph 1.1 providing that:

1.2.1 You follow the claims procedure set out in clause 2

1.2.2 Lumberjack and its authorised dealers are given reasonable opportunity after receiving notice of the claim to examine the product

1.2.3 If asked to do so by Lumberjack or its Authorised dealer, you return the product at your own cost to Lumberjack's or supplying Authorised Dealer's premises, for the examination to take place clearly stating the Returns Material Authorisation number given by Lumberjack or an Authorised Dealer.

1.2.4 The fault in question is not caused by industrial use, accidental damage, fair wear and tear, wilful damage, neglect, incorrect electrical connection, misuse, or alteration or repair of the product without approval.

1.2.5 The product has been used in a domestic environment only

1.2.6 The fault does not relate to consumable items such as blades, bearings, drive belts, or other wearing parts which can reasonably be expected to wear at different rates depending on usage.

1.2.7 The product has not been used for hire purposes.

1.2.8 The product has been purchased by you as the guarantee is not transferable from a private sale.

2. Claims Procedure

2.1 In the first instance please contact the Authorised Dealer who supplied the product to you. In our experience many initial problems with machines that are thought to be faulty due to faulty parts are actually solved by correct setting up or adjustment of the machine. A good Authorised Dealer should be able to resolve the majority of these issues much more quickly than processing a claim under the guarantee. If a return is requested by the Authorised Dealer or Lumberjack, you will be provided with a Returns Material Authorisation number which must be clearly stated on the returned package, and any accompanying correspondence. Failure to provide a Returns Material Authorisation number may result in item being refused delivery at Authorised Dealer.

2.2 Any issues with the product resulting in a potential claim under the guarantee must be reported to the Authorised Dealer from which it was purchased within 48 hours of Receipt.

2.3 If the Authorised Dealer who supplied the product to you has been unable to satisfy your query, any claims made under this Guarantee should be made directly to Lumberjack. The Claim itself should be made in a letter setting out the date and place of purchase, giving a brief explanation of the problem which has led to the claim. This letter should be then sent with proof

LUMBERJACK GUARANTEE

of purchase to Lumberjack. If you include a contact number with this it will speed your claim up.

2.4 Please note that it is essential that the letter of claim reaches Lumberjack on the last day of this Guarantee at the latest. Late claims will not be considered.

3. Limitation of Liability

3.1 We only supply products for domestic and private use. You agree not to use the product for any commercial, business or resale purposes and we have no liability to you for any loss of profit, loss of business, business interruption or loss of business opportunity.

3.2 This Guarantee does not confer any rights other than these expressly set out above and does not cover any claims for consequential loss or damage. This Guarantee is offered as an extra benefit and does not affect your statutory rights as a consumer.

4. Notice

This Guarantee applies to all product purchased from an Authorised Dealer of Lumberjack within the United Kingdom. Terms of Guarantee may vary in other countries.



CE DECLARATION OF CONFORMITY

TOOLSAVE

Unit C, Manders Ind. Est.,
Old Heath Road, Wolverhampton,
WV1 2RP.
Tel: 01902 450 470

Declares that the **RANDOM ORBITAL PALM SANDER (DS220)**
Is in compliance with the regulations included in the Directives:2006/42/EC

EC DECLARATION OF CONFORMITY

Certificate for EC-type examination delivered by Intertek Testing Services Ltd.,Shanghai,ETL Semko
Building No.86,1198 Qinzhou Road(North),Caohejing Development Zone,Shanghai 200233,China.
(Verification No.:150300747SHA-V1)

Person who declares: Bill Evans



01.04.2018

The Director

A handwritten signature in black ink, appearing to read 'Bill Evans', written in a cursive style.

Parts List

No.	Description	No.	Description
1	Housing	23	Bearing 6000RS
2	Switch	24	Washer
3	Switch cover	25	Hexagon screw M5X16
4	Bearing607 2RS	26	Rubber dust duct
5	V.S. PCB	27	Brake ring
6	Tapping screw ST3.9X19	28	Large washer
7	Cord guard	29	Rubber backing pad
8	Cord	30	Spring washer 5
9	Stator	31	Special screw M5X14
10	Dust collection box cover		
11	Filter paper		
12	Filter paper clamp		
13	Rotor		
14	Bearing6000 2RS		
15	Washer		
16	Dust box		
17	Fan		
18	Counter balance		
19	O type ring		
20	Eccentric seat		
21	Dustproof washer		
22	Bearing block		

Parts Diagram

