



**SAFETY AND OPERATING MANUAL  
TIG WELDER  
ECOTIG-160**



**ORIGINAL INSTRUCTIONS**

# TABLE OF CONTENTS

## Welcome to Autojack!

Dear Customer, Congratulations on your purchase. Before using this product for the first time, please be sure to read these instructions for use. They provide you with all the information necessary for using the product safely and to ensure its long service life. Closely observe all safety information in these instructions!

General Power Tool Safety Warnings	3
Symbol Chart	8
Technical Specification/Package Contents	9
Operation	10
Maintenance	12
Troubleshooting	13
Autojack Guarantee	14
Declaration of Conformity	17
Machine Schematic	18
Wiring Diagram	19

# GENERAL POWER TOOL SAFETY WARNINGS

## **WARNING, please read all safety warnings and instructions.**

Failure to follow the warnings and instructions may result in electric shock, fire and/or serious injury.

## **Save all warnings and instructions for future reference.**

The term "Power tool" in the warnings refers to your electric (corded) power tool or battery-operated (cordless) power tool.

### **1. Work area safety**

- a) Keep work area clean and well lit.** Cluttered or dark areas invite accidents.
- b) Do not operate power tools in explosive atmospheres, such as in the presence of flammable liquids, gases or dust.** Power tools create sparks which may ignite the dust or fumes.
- c) Keep children and bystanders away while operating a power tool.** Distractions can cause you to lose control.

### **2. Electrical safety**

- a) Power tool plugs must match the outlet. Never modify the plug in any way.** Do not use any adaptor plugs with grounded power tools. Unmodified plugs and matching outlets will reduce risk of electric shock.
- b) Avoid body contact with grounded surfaces, such as pipes, radiators, ranges and refrigerators.** There is an increased risk of electric shock if your body is grounded.
- c) Do not expose power tools to rain or wet conditions.** Water entering a power tool will increase the risk of electric shock.

- d) Do not abuse the cord. Never use the cord for carrying, pulling or unplugging the power tool. Keep cord away from heat, oil, sharp edges or moving parts.** Damaged or entangled cords increase the risk of electric shock.
- e) When operating a power tool outdoors, use an extension cord suitable for outdoor use.** Use of a cord suitable for outdoor use reduces the risk of electric shock.
- f) If operating a power tool in a damp location is unavoidable, use a residual current device (RCD) protected supply.** Use of an RCD reduces the risk of electric shock.

### **3. Personal safety**

- a) Stay alert, watch what you are doing and use common sense when operating a power tool. Do not use a power tool while you are tired or under the influence of drugs, alcohol or medication.** A moment of inattention while operating power tools may result in serious personal injury.
- b) Use personal protective equipment. Always wear eye protection.** Protective equipment such as dust mask, non-skid safety shoes, hard hat, or hearing protection used for appropriate conditions will reduce personal injuries.
- c) Prevent unintentional starting. Ensure the switch is in the off position before connecting to power source and/or battery pack, picking up or carrying the tool.** Carrying power tools with your finger on the switch or energizing power tools that have the switch on invites accidents.
- d) Remove any adjusting key or wrench before turning the power tool on.** A wrench or a key left attached to a rotating part of the power tool may result in personal injury.

# GENERAL POWER TOOL SAFETY WARNINGS

**e) Do not overreach. Keep proper footing and balance at all times.** This enables better control of the power tool in unexpected situations.

**f) Dress properly. Do not wear loose clothing or jewellery. Keep your hair, clothing and gloves away from moving parts.** Loose clothes, jewellery or long hair can be caught in moving parts.

**g) If devices are provided for the connection of dust extraction and collection facilities, ensure these are connected and properly used.** Use of dust collection can reduce dust-related hazards.

## 4. Power tool use and care

**a) Do not force the power tool. Use the correct power tool for your application.** The correct power tool will do the job better and safer at the rate for which it was designed.

**b) Do not use the power tool if the switch does not turn it on and off.** Any power tool that cannot be controlled with the switch is dangerous and must be repaired.

**c) Disconnect the plug from the power source and/or the battery pack from the power tool before making any adjustments, changing accessories, or storing power tools.** Such preventive safety measures reduce the risk of starting the power tool accidentally.

**d) Store idle power tools out of the reach of children and do not allow persons unfamiliar with the power tool or these instructions to operate the power tool.** Power tools are dangerous in the hands of untrained users.

**e) Maintain power tools. Check for misalignment or binding of moving parts, breakage of parts and any other condition that may affect the power tool's operation. If damaged, have the power tool repaired before use.** Many accidents are caused by poorly maintained power tools.

**f) Keep cutting tools sharp and clean.** Properly maintained cutting tools with sharp cutting edges are less likely to bind and are easier

**g) Use the power tool, accessories and tool bits etc. in accordance with these instructions, taking into account the working conditions and the work to be performed.** Use of the power tool for operations different from those intended could result in a hazardous situation.

## 5. Service

**a) Have your power tool serviced by a qualified repair person using only identical replacement parts.** This will ensure that the safety of the power tool is maintained.

**b) If the replacement of the supply cord is necessary, this has to be done by the manufacturer or its agent in order to avoid a safety hazard.**

# GENERAL POWER TOOL SAFETY WARNINGS

## 7 Additional Safety Instructions for welders

**Welders have many sources of danger. It is therefore particularly important for the welder to comply with the following rules so as not to place themselves or others in danger and to avoid endangering people and equipment.**

- a) Have all work on the mains voltage system, for example on cables, plugs, sockets, etc., performed only by trained electricians. This particularly applies to configuring intermediate cables.
- b) If an accident occurs, disconnect the welding power source from the mains immediately.
- c) If electric touch voltages occur, switch off the welding set immediately and have it checked by an expert.
- d) Always check for good electrical contacts on the welding current side.

- e) Wear insulating gloves on both hands for welding. These offer protection from electric shocks (idling voltage in the welding circuit), harmful radiation (Heat and UV radiation) and from glowing metal and slag spatter.
- f) Wear firm, insulated footwear. Your shoes should also protect you in wet conditions. Open-toed footwear is not suitable since falling droplets of glowing metal will cause burns.
- g) Wear suitable clothing, do not wear synthetic clothes.
- h) Do not look into the arc with unprotected eyes, use only a welding safety shield with the proper safety glass in compliance with DIN standards. In addition to light and heat, which may cause dazzling and burns, the arc also gives off UV radiation. Without proper protection, this invisible ultraviolet radiation causes very painful conjunctivitis, which will only be noticeable several hours later. In addition, UV radiation will cause sunburn-type symptoms on unprotected parts of the body.
- i) Personnel or assistants in the vicinity of the arc must also be notified of the dangers and provided with the required protection; if necessary install safety walls.
- j) Ensure adequate ventilation for welding, particularly in small rooms since the process causes smoke and harmful gases.
- k) Do not carry out any welding work on tanks that have been used to store gases, fuels, mineral oil or the like, even if they have been empty for a lengthy period of time, since any residue will result in a danger of explosion.

# GENERAL POWER TOOL SAFETY WARNINGS

l) Special regulations apply in areas where there is a potential risk of fire and/or explosion.

m) Welds that are exposed to large stresses and must comply with safety requirements may only be completed by specially trained and approved welders. Examples of such welds include pressure vessels, rails, trailer hitches, etc.

n) It must be noted that the protective conductor in electrical systems of appliances may be destroyed by the welding current in the event of negligence, for example if the earth terminal is placed on the welding set casing to which the protective conductor of the electrical system is connected. The welding work is completed on a machine with a protective conductor connection. It is therefore possible to weld on the machine without having connected the earth terminal to it. In this case the welding current will flow from the earth terminal through the protective conductor to the machine. The high welding current may cause the protective conductor to melt.

o) The fuses on the supply cables to the mains sockets must comply with the relevant regulations (VDE 0100). To comply with these regulations, only fuses or circuit breakers suitable for the cross-section of the cables may be used (for earthing contact sockets max. 16 A fuses or 16 A circuit breakers). The use of too high a fuse may result in the cable burning and fire damage to the building.

## 8. Additional Safety Instructions for Constricted and wet areas

When working in constricted, wet or hot areas, use insulating supports and intermediate layers as well as slip-on gloves made of leather or other non-conductive materials to insulate your body against the floor, walls, conductive parts of the machine and the like.

If you use small welding transformers for welding in places with an increase electrical risk, for example in constricted areas with conductive walls, (tanks, pipes, etc.), in wet areas (which make work clothes wet) and in hot areas (perspiration on work clothes), the output voltage of the welding set when idling must not exceed 48 V (effective value).

Therefore, the appliance may not be used for these purposes because its output voltage is higher than this.

# GENERAL POWER TOOL SAFETY WARNINGS

## 9. Additional Safety Instructions for safety clothing

- a) While working, the welder must protect his entire body from radiation and burns by wearing suitable clothing and a face guard.
- b) Slip-on gloves made of a suitable material (leather) must be worn on both hands. They must be in perfect condition.
- c) Suitable aprons must be worn to protect clothing from sparks and burns. A safety suit and if necessary, head protection must be worn if required by the type of work in question, e.g. overhead welding.
- d) The safety clothing used as well as all accessories must comply with the "Personal Safety Equipment" directive.

## 10. Additional Safety Instructions for Protection from radiation and burns.

- a) Provide information about the risk to eyes at the working site in the form of a poster with the wording "Caution – do not look at the flames". Workplaces are to be screened off wherever possible so that personnel in the vicinity are protected. Unauthorized persons are to be kept away from the welding work.
- b) The walls in the immediate vicinity of stationary workplaces should not have a light color or a sheen. Windows up to head height are to be protected against radiation passing through them or reflecting off them, for example by coating them with a suitable paint.

Do not store or use the equipment in wet conditions or in the rain. Use the equipment only indoors.

## 11. Using an Extension Cable.

- a) If an extension cable is required, use an approved triple core extension cable suitable for the power input of the tool.
- b) Grounded tools always require a three wire extension cable.
- c) As the distance from the supply outlet increases you must use a heavier gauge extension cable. Using extension cables with inadequately sized wire causes a serious drop in voltage, resulting in loss of power and possible tool damage.
- d) The smaller the gauge number of the wire the greater the capacity of the cord.
- e) When using a cable reel, always unwind the cable completely.

# SYMBOL CHART



**Danger! – Read the operating instructions to reduce the risk of injury.**



**Caution! Wear safety goggles.**



**Caution! Wear a face mask.**



**Caution! Risk of Injury!**



**Caution! Wear a welding mask with the cutting shade lens.**



# TECHNICAL SPECIFICATION

<b><u>SPECIFICATION</u></b>	<b>ECOTIG 160</b>
Rated Input Voltage	1ph AC 230v
Frequency	50/60 Hz
Rated Input Capacity	6.78 Kw
Rated Input Current	29.5 A
Rated Duty Cycle	30%
Welding Current 10min/30%	160
Welding Current 10min/60%	120
Welding Current 10min/100%	88
No Load Voltage	62 V
Rated Working Voltage	16.4 V
TIG Current Range	10 ~ 160A
MMA Current Range	10 ~ 140A
Efficiency	85%
Protection Class	IP21S
Insulated Grade	H
Cooling	Air Cooled
Dimensions (mm)	395 x 145 x 290 mm
Net Weight	7 KG
Gross Weight	8.8 KG

## **Package Contents**

- ECOTIG 160 Welder
- 3Mtr WP17 TIG Torch
- 1.8Mtr 200A Electrode Holder
- 1.2Mtr 200A Earth Clamp
- Brush & Hammer
- Mask with Filter
- Instruction Manual

# OPERATION

The image on the right shows how the welder should be set up to TIG weld.

The gas bottle is connected into the rear of the welder via a gas hose and regulator.

The TIG torch is connected via the negative terminal and the earth clamp in the positive.

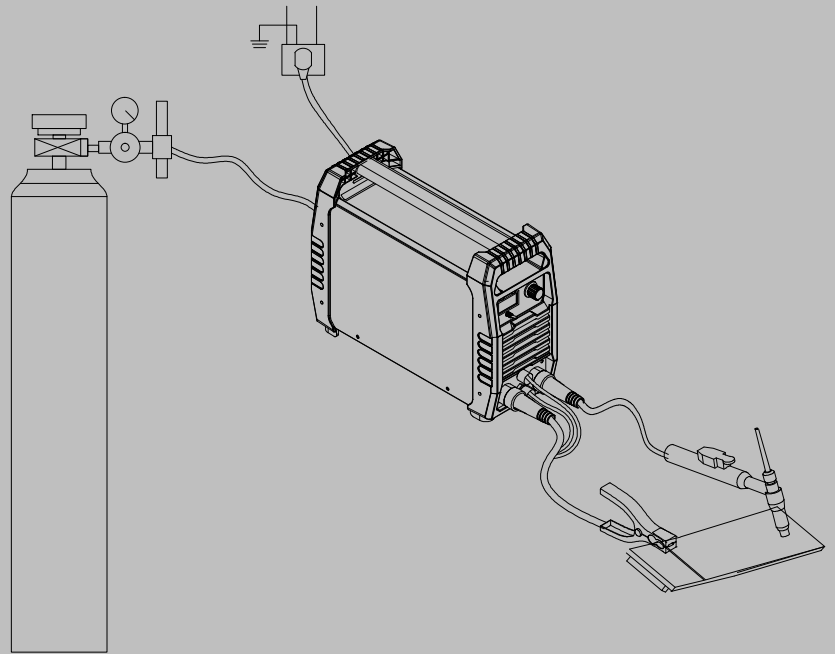

When the above connections have been carried out, you can turn on the welder by the main power switch on the rear. The indicator light will then light up to show that there is power. The welding current then has to be adjusted corresponding to your workpiece. Once the settings are correct, you must connect the earth clamp to a clean piece of metal without rust. The torch can then be used to strike an arc, to do this, you hold the torch a few mm away from the workpiece and press the trigger which ignites the argon gas to begin a weld. The distance between the tungsten needle and the workpiece is dependent on the size of the tungsten and thickness of the metal.

To make a clean seamless weld, it is advised to hold the torch at a 75-degree angle from the workpiece. The distance between the torch and workpiece must be maintained along the length of the weld as well as the speed.

Once the weld is complete, add a small amount of wire to the end of the weld pool before pulling the torch away to keep it clean.

# OPERATION

When ARC welding, your amperage/current should be determined by the electrode size, the knob adjusts this setting.

Before welding, ensure that you have your welding mask on and set to the arc function if applicable.

The electrode should be around 1.5mm to 3mm away from the workpiece until the arc is made, once the arc has started, move the rod in a steady motion in one direction across where you would like your weld. Once you have finished your weld, pull the rod away from the workpiece and remove any excess weld spatter with the wire brush that is supplied with your welder and a hammer. Before starting a new weld, inspect the rod used to make sure that the tip is concentric. If not, you can re-sharpen the tip using a grinding wheel or change the rod completely.

The image below shows how this welder should be set-up for arc welding.

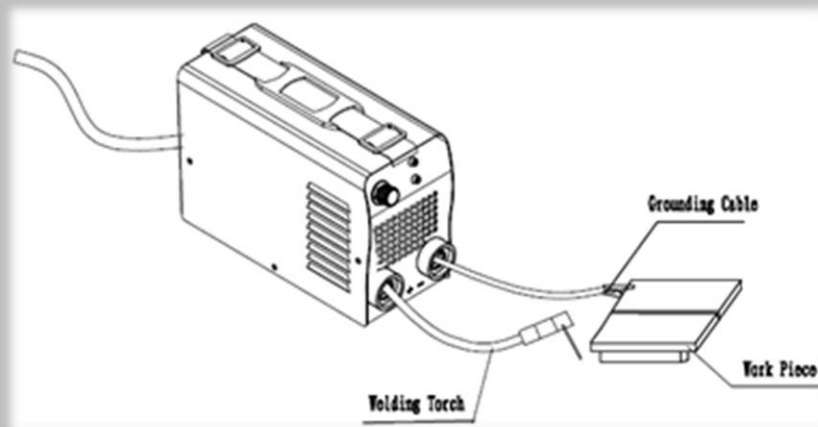

When the welder has been used for a prolonged period of time, the overheat light may illuminate.

If this happens, please stop using the machine until it goes out.

Turning the machine off when in this state can cause damage to an internal PCB.

# MAINTENANCE

The following points will aid with keeping your TIG welder in good condition to ensure peak performance:

- Regularly clear metallic dust from inside of the machine (use a low-pressure air gun)
- Keep the welder in a dry place when not in use
- Check that the earth clamp can clamp sufficiently, replace if necessary
- Make sure all cables are in good condition with no nicks or degradation to the sheathing
- Check all connections are usable with no oxidization or wear to any contacts
- Check to make sure the fan works when welding

Monthly examination	Using a low pressure air gun, clear the inside of the machine, especially any metallic dust around the internal PCB's or heatsink/radiators. Check the earths inside of the machine for rust and ensure that all bolts are tight.
Quarter-yearly examination	Check the currents match with the value given on the display. The current can be measured using a clamp meter for ampere's.
Yearly examination	Test the impedance across the main PCB and case. If it is below 1M Ohm, the PCB could be damaged and will need to be changed.

# TROUBLESHOOTING

Number	Fault	Failure Cause	Troubleshooting
1	Fan not working or slower than usual	Faulty fan	Replace the fan
		Wire broken	Replace/repair the wiring
2	No HF Arc when pressing trigger	Torch switch failed	Change switch in the torch
		Control PCB failed	Change control PCB
		Wires in torch broken	Replace/repair wiring in the torch
3	No gas output	No gas coming through	Check gas line
		Control PCB failed	Change control PCB
		Solenoid valve failed	Change solenoid valve
4	Indicator Light	Welder overheated	Wait 10 minutes, retry
		Thermal relay failed	Replace thermal relay
		Over/under voltage protection (+/- 15%)	When normal voltage is applied, wait 10 minutes and retry
5	Current knob problem	Potentiometer failed	Replace potentiometer
		Control PCB failed	Replace control PCB
		Potentiometer wiring broken	Replace/repair wiring for potentiometer
6	Poor arc	Wrong connection for torch	Check operation instructions and retry
		Argon gas not pure	Use 99.99% Argon gas
		Tungsten electrode or needle damaged	Replace electrode or needle with correct one for application
7	Tripped electrics	Power supply fault	Check power supply
8	Tungsten melted	Tungsten electrode contacted the work piece	Change tungsten
		Incorrect tungsten used	Change tungsten to correct one for application
9	Poor air protection	Argon gas not pure	Use 99.99% pure argon
			Enough time for post-gas and pre-flow
			Clean workpiece before welding
			Change shielding gas flow
			Increase nozzle size or electrode length

# AUTOJACK GUARANTEE

## 1. Guarantee

1.1 Autojack guarantees that for a period of 12 months from the date of purchase the components of qualifying products (see clauses

1.2.1 to 1.2.8) will be free from defects caused by faulty construction or manufacture

1.2 During this period, Autojack, will repair or replace free of charge any parts which are proved to be faulty in accordance with paragraph 1.1 providing that:

1.2.1 You follow the claims procedure set out in clause 2.

1.2.2 Autojack and its Authorised Dealers are given reasonable opportunity after receiving notice of the claim to examine the product.

1.2.3 If asked to do so by Autojack or its Authorised Dealer, you return the product at your own cost to Autojack's or the supplying Authorised Dealer's Premises, For the examination to take place clearly stating the Returns Material Authorisation Number given by Autojack or an Authorised Dealer.

1.2.4 The fault in question is not caused by industrial use, accidental damage, fair wear and tear, wilful damage, neglect, incorrect electrical connection, misuse, alteration or repair of the product without approval.

1.2.5 The product has been used in a domestic environment only.

1.2.6 The fault does not relate to consumable items such as blades, bearings, drive belts or other wearing parts which can reasonably be expected to wear at different rates depending on usage.

1.2.7 The product has not been used for hire purposes.

1.2.8 The product has been purchased by you, as the guarantee is not transferable from a private sale.

# AUTOJACK GUARANTEE

## 2. Claims Procedure

2.1 In the first instance please contact the Authorised Dealer who supplied the product to you. In our experience many initial problems with machines that are thought to be fault due to faulty parts are actually solved by correct setting up or adjustment of the machine. A good Authorised Dealer should be able to resolve the majority of these issues much more quickly than processing a claim under the guarantee. If a return is requested by the Authorised Dealer or Autojack, you will be provided with a Returns Material Authorisation Number which must be clearly stated on the returned package, and any accompanying correspondence.

Failure to provide a Returns Material Authorisation Number may result in item being refused delivery.

2.2 Any issues with the product resulting in a potential claim under the guarantee must be reported to the Authorised Dealer from which it was purchased within 48 hours of receipt

1.3 If the authorized Dealer who supplied the product to you has been unable to satisfy your query, any claims made under this guarantee should be made in a letter setting out the date and place of purchase, giving a brief explanation of the problem which has led to the claim. This letter should be then sent with proof of purchase to Autojack. If you include a contact number with this it will speed your claim up.

1.4 Please note that it is essential that the letter of claim reaches Autojack on the last day of this guarantee at the latest. Late claims will not be considered.

# AUTOJACK GUARANTEE

## **3. Limitation of Liability**

3.1 We only support products for domestic and private use. You agree not to use the product for any commercial, business or resale purposes and we have no liability to you for any loss of profit, loss of business, business interruption or loss of business opportunity.

3.2 This guarantee does not confer any rights other than these expressly set out above and does not cover any claims for consequential loss or damage. This guarantee is offered as an extra benefit and does not affect your statutory rights as a consumer.

## **4. Notice**

This guarantee applies to all product purchased from an Authorised Dealer of Autojack within the United Kingdom. Terms of guarantee may vary in other countries.



# DECLARATION OF CONFORMITY

## CE DECLARATION OF CONFORMITY

Toolsave  
Unit C, Manders Ind Est.,  
Old Heath Road, Wolverhampton,  
WV1 2RP.

Declares that the ECOTIG-160 Welder  
is in compliance with the regulations included in the Directives:

2006/42/EC

## EC DECLARATION OF CONFORMITY

Certificate for EC-type examination delivered  
by AV Technology Ltd. Unit 2 Easter Court,  
Europa Boulevard, Warrington, Cheshire,

WA5 7ZB

(Certificate No.: GB/1067/5862/16)

Person who declares: Bill Evans



27/08/2020  
The Director

A handwritten signature in black ink, appearing to be 'Bill Evans', written over a white rectangular background.

# MACHINE SCHEMATIC

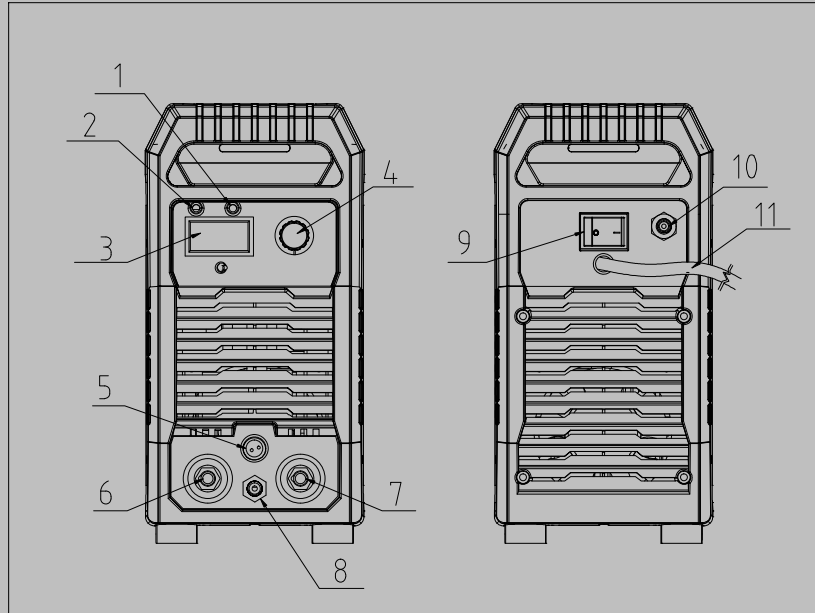

- |                    |                    |
|--------------------|--------------------|
| 1. Overheat Light  | 7. Negative Socket |
| 2. Power Light     | 8. Gas Connection  |
| 3. Digital Display | 9. Power Switch    |
| 4. Power Light     | 10. Gas Input      |
| 5. Remote Socket   | 11. Power Cord     |
| 6. Positive Socket |                    |

# Wiring Diagram

