



SAFETY AND OPERATING MANUAL
20mm Floor Standing Drill Press
DP20-1630F



ORIGINAL INSTRUCTIONS



DP20-1630F

TABLE OF CONTENTS

Welcome to Lumberjack!

Dear customer, Congratulations on your purchase. Before using the product for the first time please be sure to read these instructions for use.

They provide you with all information necessary for using the product safely and to ensure its long service life.

Closely observe all safety information in these instructions!

| | |
|--|-----------|
| General Power Tool Safety Warnings..... | 01 |
| Symbols & Cable Rating Chart | 05 |
| Machine Details and Product Features..... | 06 |
| Assembly..... | 08 |
| Adjustments..... | 12 |
| Operation, Maintenance and Service..... | 15 |
| Lumberjack Guarantee..... | 17 |
| Declaration of Conformity..... | 19 |
| Parts List..... | 20 |
| Parts Diagram..... | 22 |



DP20-1630F

GENERAL POWER TOOL SAFETY WARNINGS

WARNING Read all safety warnings and all instructions. Failure to follow the warnings and instructions may result in electric shock, fire and/or serious injury.

Save all warnings and instructions for future reference. The term "power tool" in the warnings refers to your electric (corded) power tool or battery-operated (cordless) power tool.

1. Work area safety

a) Keep work area clean and well lit. Cluttered or dark areas invite accidents.

b) Do not operate power tools in explosive atmospheres, such as in the presence of flammable liquids, gases or dust. Power tools create sparks which may ignite the dust or fumes.

c) Keep children and bystanders away while operating a power tool. Distractions can cause you to lose control.

2. Electrical safety

a) Power tool plugs must match the outlet. Never modify the plug in any way. Do not use any adapter plugs with grounded power tools. Unmodified plugs and matching outlets will reduce risk of electric shock.

b) Avoid body contact with grounded surfaces, such as pipes, radiators, ranges and refrigerators. There is an increased risk of electric shock if your body is grounded.

c) Do not expose power tools to rain or wet conditions. Water entering a power tool will increase the risk of electric shock.

d) Do not abuse the cord. Never use the cord for carrying, pulling or unplugging the power tool. Keep cord away from heat, oil, sharp edges or moving parts. Damaged or entangled cords increase the risk of electric shock.

e) When operating a power tool outdoors, use an extension cord suitable for outdoor use. Use of a cord suitable for outdoor use reduces the risk of electric shock.

f) If operating a power tool in a damp location is unavoidable, use a residual current device (RCD) protected supply. Use of an RCD reduces the risk of electric shock.

3. Personal safety

a) Stay alert, watch what you are doing and use common sense when operating a power tool. Do not use a power tool while you are tired or under the influence of drugs, alcohol or medication. A moment of inattention while operating power tools may result in serious personal injury.

b) Use personal protective equipment. Always wear eye protection. Protective equipment such as dust mask, non-skid safety shoes, hard hat, or hearing protection used for appropriate conditions will reduce personal injuries.

c) Prevent unintentional starting. Ensure the switch is in the off position before connecting to power source and/or battery pack, picking up or carrying the tool. Carrying power tools with your finger on the switch or energising power tools that have the switch on invites accidents.

d) Remove any adjusting key or wrench before turning the power tool on. A wrench or a key left attached to a rotating part of the power tool may result in personal injury.



GENERAL POWER TOOL SAFETY WARNINGS

e) Do not overreach. Keep proper footing and balance at all times. This enables better control of the power tool in unexpected situations.

f) Dress properly. Do not wear loose clothing or jewellery. Keep your hair, clothing and gloves away from moving parts. Loose clothes, jewellery or long hair can be caught in moving parts.

g) If devices are provided for the connection of dust extraction and collection facilities, ensure these are connected and properly used. Use of dust collection can reduce dust-related hazards.

4. Power tool use and care

a) Do not force the power tool. Use the correct power tool for your application. The correct power tool will do the job better and safer at the rate for which it was designed.

b) Do not use the power tool if the switch does not turn it on and off. Any power tool that cannot be controlled with the switch is dangerous and must be repaired.

c) Disconnect the plug from the power source and/or the battery pack from the power tool before making any adjustments, changing accessories, or storing power tools. Such preventive safety measures reduce the risk of starting the power tool accidentally.

d) Store idle power tools out of the reach of children and do not allow persons unfamiliar with the power tool or these instructions to operate the power tool. Power tools are dangerous in the hands of untrained users.

e) Maintain power tools. Check for misalignment or binding of moving parts, breakage of parts and any other condition that may affect the power tool's operation. If damaged, have the power tool repaired before use. Many accidents are caused by poorly maintained power tools.

f) Keep cutting tools sharp and clean. Properly maintained cutting tools with sharp cutting edges are less likely to bind and are easier to control.

g) Use the power tool, accessories and tool bits etc. in accordance with these instructions, taking into account the working conditions and the work to be performed. Use of the power tool for operations different from those intended could result in a hazardous situation.

5. Service

a) Have your power tool serviced by a qualified repair person using only identical replacement parts. This will ensure that the safety of the power tool is maintained.

b) If the replacement of the supply cord is necessary, this has to be done by the manufacturer or its agent in order to avoid a safety hazard.

6. Battery Tool Use and Care

a) Recharge only with the charger specified by the manufacturer. A charger that is suitable for one type of battery pack may create a risk of fire when used with another battery pack.

b) Use power tools only with specifically designated battery packs. Use of any other battery packs may create a risk of injury or fire.



GENERAL POWER TOOL SAFETY WARNINGS

c) When Battery pack is not in use, keep it away from other metal objects, like paper clips, coins, keys, nails, screws or other small metal object that can make a connection from one terminal to another. Shorting the battery terminals together may cause burns or a fire.

D) User abusive conditions, liquid may be ejected from the battery; Avoid contact. If contact accidentally occurs, flush with copious amounts of water. If liquid contacts eyes, seek medical help immediately. Liquid ejected from the batter may cause irritation or burns.

7. Additional Safety and working Instructions

7.1. Dust from materials such as lead-containing coatings, some wood types, minerals and metals can be harmful to one's health and cause allergic reactions, leading to respiratory infections and/or cancer. Materials containing asbestos may only be worked by specialists. Observe the relevant regulations in your country for the materials to be worked.

7.2. Prevent dust accumulation at the workplace. Dust can easily ignite.

8 Additional Safety Warning for Bench Drills

8.1 Always wear hairnet for long hair, and make sure you are wearing safety goggles.

8.2 Do not wear gloves, ties or loose clothing.

8.3 while drilling make sure the piece is secured with a vice; never hold the workpiece by hand! Never keep your fingers near where they could touch the drill in case the piece moves suddenly.

8.4 Do not use the machine until it has been properly installed in accordance with the instructions provided.

8.5 Do not switch on the machine until all pieces have been firmly tightened together.

8.6 Do not use the machine if it is damaged or functioning badly.

8.7 Perform all adjustments before switching on the machine, make sure to set table height or depth stop to prevent the drill entering the table.

8.8 (If Applicable) Always make sure chick key is removed before use.

8.9 Before switching on the machine check the chuck has been mounted correctly and securely, and that the safety guard is engaged.

8.10 In operations stick to recommended speeds for the drilling accessories and material being used.

8.11 Switch off the power before handling the drill or chuck. Once finished remove drill and clean the table before leaving the machine.

8.12 Always lock the on/off switch when leaving the machine.

GENERAL POWER TOOL SAFETY WARNINGS

9. Using an Extension Cable.

9.1. If an extension cable is required, use an approved triple core extension cable suitable for the power input of the tool.

9.2. Grounded tools always require a three wire extension cable.

9.3. As the distance from the supply outlet increases you must use a heavier gauge extension cable. Using extension cables with inadequately sized wire causes a serious drop in voltage, resulting in loss of power and possible tool damage.

9.4. The smaller the gauge number of the wire the greater the capacity of the cord.

9.5. When using a cable reel, always unwind the cable completely.



SYMBOLS AND POWER RATING CHART



Danger! – Read the operating instructions to reduce the risk of injury.



Caution! Wear safety goggles.



Caution! Wear ear defenders. The impact of noise can cause damage to hearing.



Caution! Risk of Injury! Do not reach into the running saw blade.



Caution! Wear a dust mask.

| Amperes | 7.5M | 15M | 25M | 30M | 45M | 60M |
|-------------|------|-----|-----|-----|-----|-----|
| 0 – 2.0 | 6 | 6 | 6 | 6 | 6 | 6 |
| 2.1 – 3.4 | 6 | 6 | 6 | 6 | 6 | 6 |
| 3.5 - 5.0 | 6 | 6 | 6 | 6 | 10 | 15 |
| 5.1 – 7.1 | 10 | 10 | 10 | 10 | 15 | 15 |
| 7.1 – 12.0 | 15 | 15 | 15 | 15 | 20 | 20 |
| 12.1 – 20.0 | 20 | 20 | 20 | 20 | 25 | - |

MACHINE DETAILS AND PRODUCT FEATURES

Machine Details

Usage

Your bench drill has been designed for the drilling of holes in metal, plastics and wood. It has not been designed for commercial use.

Specifications:

Mains Voltage - 230V/50Hz

Power – 600W

Motor Speed – 1400min⁻¹

Speed Range – 12

(180/250/300/400/480/580/970/
1280/1410/1540/2270/2740RPM)

Swing – 380mm

Spindle Taper – MT2

Max. Spindle Travel – 80mm

Drill Capacity – 20mm

Chuck Capacity – 16mm

Max. Distance From Chuck to the table –
660mm

Max. Distance From Chuck to the base –
1150mm

Table Size – 305X305mm

Base Size – 480X290mm

Over all Height – 1630mm

Nett Weight - 60Kgs

Gross Weight – 64Kgs

Package Contents:

A Table x 1

B Column Support Asm x 1

C Owner's Manual x 1

D Box of loose parts x 1

E Bag of loose parts x 1

F Base x1

G Head Asm x 1

H Chuck guard Asm x 1

Loose parts list:

Hex M10 head screw x 4

M5 Hex "L" Wrench x 1

M3 Hex "L" Wrench x 1

Clamp-column lock x 1

Crank(with set screw) x 1

Feed handle x 3

Chuck x 1

Chuck Key x 1

Idler pulley assembly x 1

Belt "V" M24 x 1

Belt "V" M26 x 1

Key-drift x 1

The design of the model may be different depending on manufacturing changes.

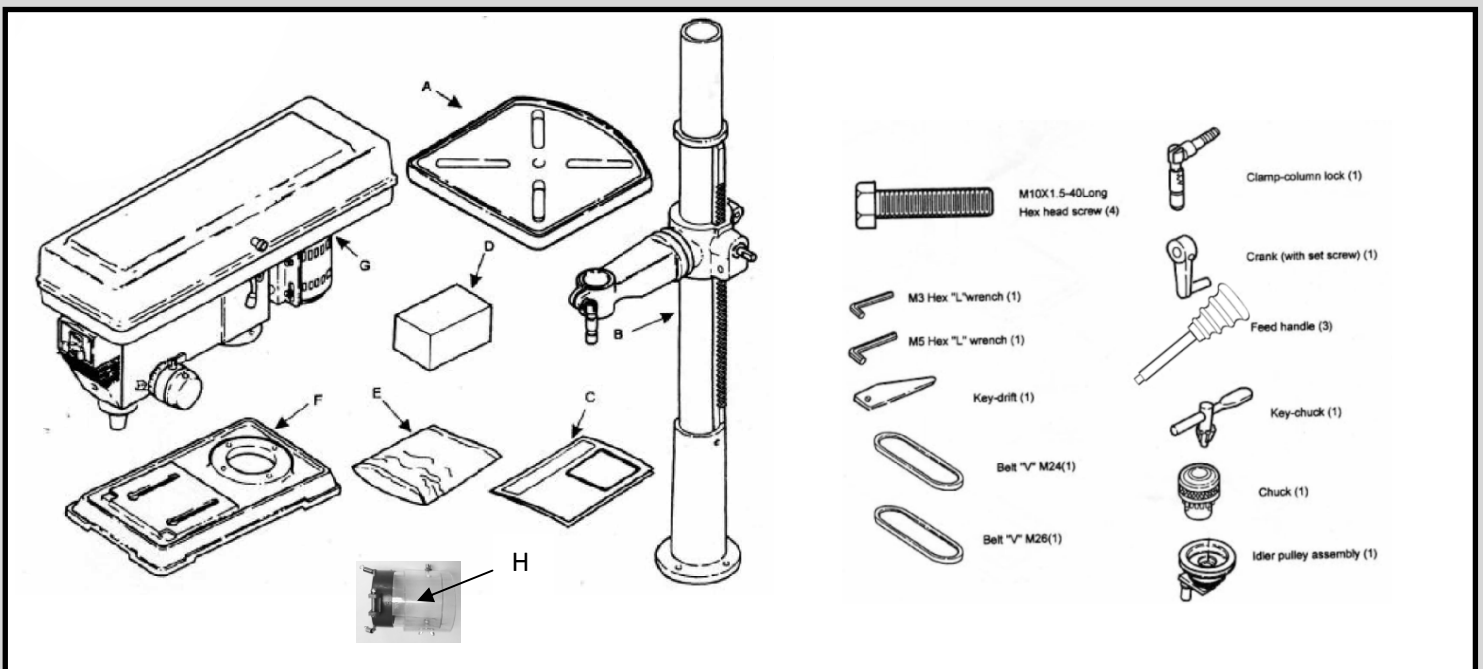

MACHINE DETAILS AND PRODUCT FEATURES

Features

1. Belt Guard
2. Belt Tension Lock Handle
3. Belt Tension Handle
4. Head LOCK
5. Feed Handle
6. Column Collar
7. Table Support
8. Table Crank
9. Rack
10. Base
11. Column Support
12. Column
13. Table
14. Depth Scale
15. Depth Scale Indicator
16. Depth Scale Lock
17. Spring Cap
18. Chuck
19. Arm
20. Table Bevel Lock(Under Table)
21. Table Lock
22. Bevel Scale
23. Support Lock
24. Chuck Key
25. Chuck Guard

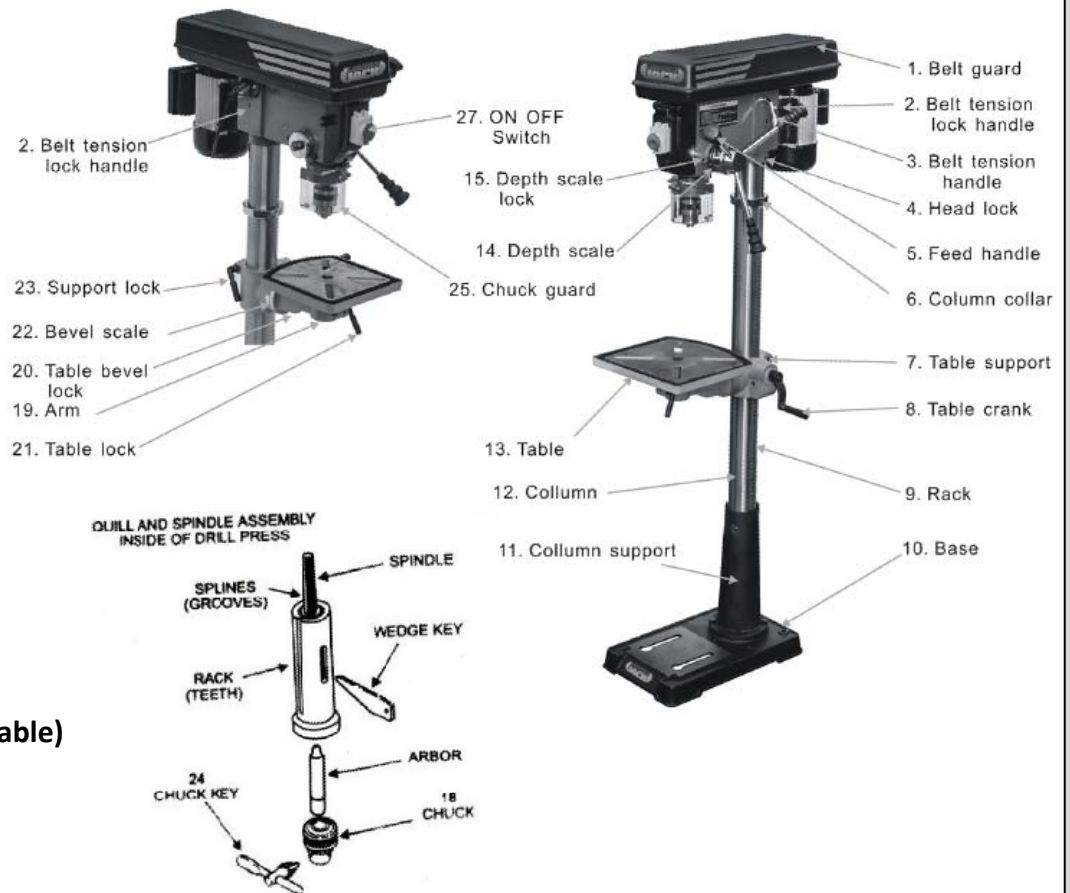

Unpacking Instructions

1. Separate all parts from packaging materials and check all items are accounted for.
2. Remove the protective oil that is applied to the table and column. Any ordinary grease and spot remover will do.
3. Apply a coat of paste wax to the table and column to prevent rust. Wipe all parts thoroughly with clean dry cloth.

ASSEMBLY INSTRUCTIONS

Assembly

Avoid unintentional starting of the machine. During assembly and for all work on the machine, the power plug must not be connected to the mains supply.

Carefully remove all parts included in the delivery from their packaging.

Remove all packaging material from the machine and the accessories provided.

Before starting the operation of the machine for the first time, check if all parts listed in the box content section have been supplied

Note: Check the power tool for possible damage. Before further use of the machine, check that all protective devices are fully functional. Any lightly damaged parts must be carefully checked to ensure flawless operation of the tool. All parts must be properly mounted and all conditions fulfilled that ensure faultless operation.

Damaged protective devices and parts must be immediately replaced by an authorised service centre.

Base and column & table assembly

1. Position the base (A) on the floor. Remove the protective covering and discard.
2. Remove protective sleeve from the column (B) and discard. Place the column assembly on the base, align the holes in the column support (C) with the holes in the base.
3. Locate three long bolts from the parts bag.
4. Install a bolt in each hole through the column support (C) and the base and tighten with the adjustable wrench.
5. Loosen set screw (A) in column collar (B) with 3mm hex. Key (C) and remove collar and rack (D) from the column.

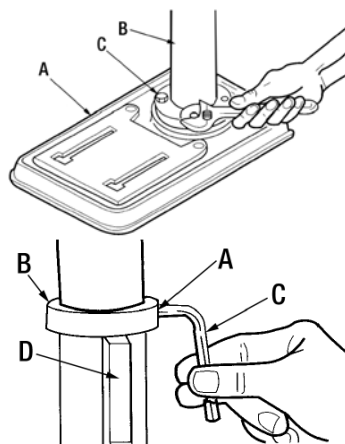

6. Find the elevation worm gear shaft (A) in the loose parts bag. Insert the elevation shaft into the table support (B) and extend the shaft through the opening as far as possible. The crank handle (C) is to be installed on the elevation shaft, the set screw (D) is to be aligned with the flat portion of the shaft. The crank is to be positioned as close to the arm support as possible, then tighten the set screw.

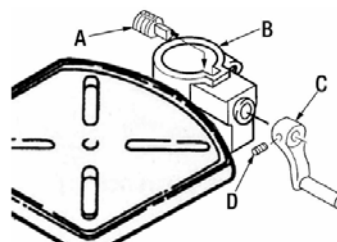

7. With the long smooth end of the rack (A) pointing upwards, slide rack down through the large round opening in the table support (B). Engage rack in gear mechanism found inside the opening of the table support.

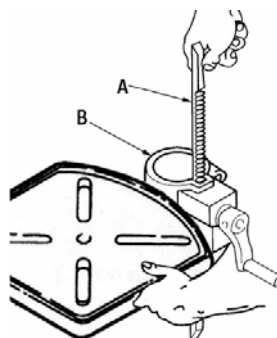

ASSEMBLY INSTRUCTIONS

8. While holding the rack (A) and table support (B) in an engaged position, slide both down over the column (C). Slide rack down the column until the rack is positioned against the lower column support (D).

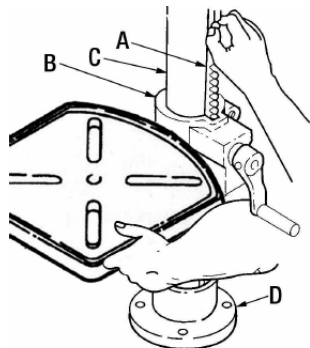

9. Replace column collar (A) and position it bevel side down over the rack (B). Tighten set screw (C) in collar with 3mm hex. key (D). To let the rack slide when the table is swung to the left or right around the column, the collar must sit loosely over the rack and should not be angled on the column. Only tighten set screw enough to keep the collar in place, otherwise the collar may break due to excessive pressure.

NOTE: To avoid column or collar damage, do not overtighten set screw.

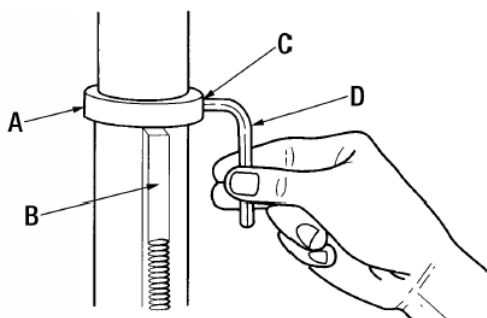

10. Locate the support lock handle (A) in loose parts bag and tighten by hand.

11. To minimize crank backlash; tighten the support lock handle and rotate the elevation worm shaft clockwise with the crank handle. Loosen the set screw in the crank and reposition it as close to the table support as possible. Tighten set screw in the crank handle.

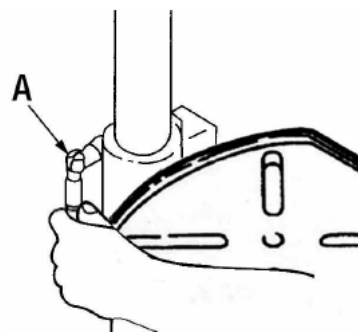

Installation the head

1. Remove the protective covering from the head assembly.
2. Carefully lift the head above the column and slide it down on the column as far as it will go. Align the head with the table and the base.
3. Using a 4mm hex. Key, tighten the head set screws on the right side of the head.

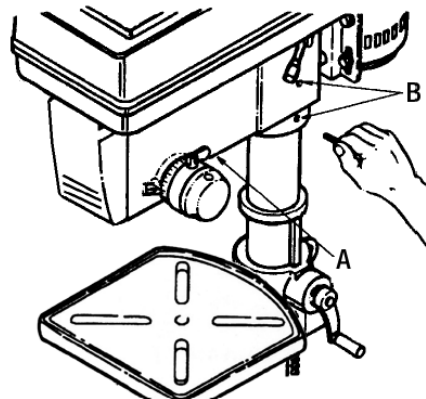

Installing pulley cover knob or locking pulley cover

1. Install the knob (A) Fig.13B to the pulley cover (B) using a small pan head screw (C) as shown in Option #1.
2. For safety reasons, user may be required to lock the pulley cover to prevent easy access to the pulleys. This can be done by only using the small pan head screw (C). Close the pulley cover and screw panhead screw through the cover and into the tab (D) as shown in Option #2.

ASSEMBLY INSTRUCTIONS

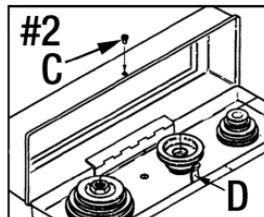
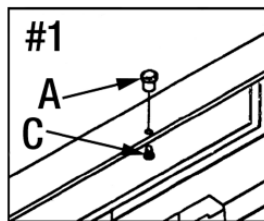
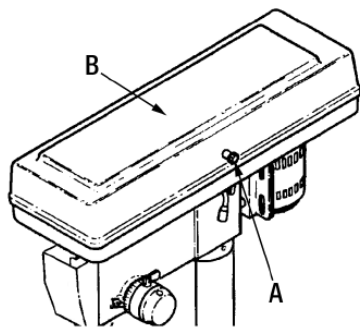

Installation the chuck

1. Locate the chuck in the box of parts.
2. Clean out the tapered hole in the chuck, also clean the spindle nose with a clean cloth. Make sure there are no foreign particles sticking to the surfaces. The slightest piece of dirt on the spindle nose or the chuck will prevent the chuck from seating properly. This will cause the drill to "wobble".

NOTE: If the tapered hole in the chuck is extremely dirty, use a cleaning solvent on a clean cloth.

3. Tighten the Phillips head screws of the chuck guard to the quill shaft.
4. Push the chuck up on the spindle nose as far as it will go.
5. Turn the chuck sleeve clockwise and open the chuck jaws completely.
6. Lightly tap the nose of the chuck with a piece of wood to insure the proper seating of the chuck on the spindle.

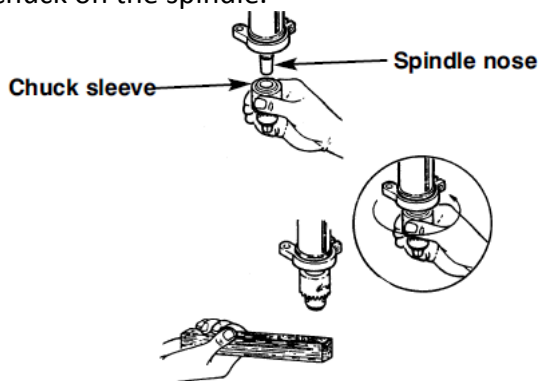

Installation the feed handles

1. Locate the three feed handles among the loose parts.
2. Screw the feed handle tightly into the threaded holes in the hub.

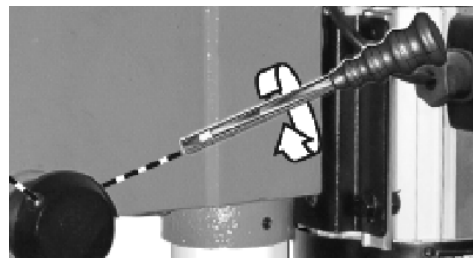

Installing the belt guard knob

1. To attach the belt guard knob, use the knob and a pan head screw from the loose parts bag. Insert the pan head screw into the belt guard and screw knob. Tighten.

WARNING! To avoid possible injury, keep the guard in place and in proper working order while operating.

Belt guard knob

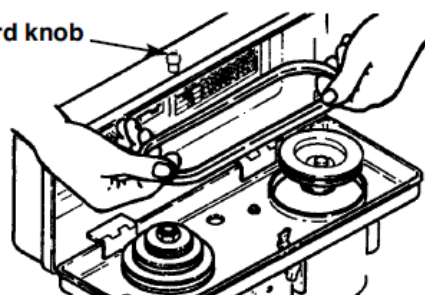

Tensioning the belt

NOTE: The drill press is shipped with the belt installed, but it should be properly tensioned before use.

1. Lift the guard (A) from the right side and keep it opened.
2. Release the belt tension lock knobs (B) located on both sides of the drill press head. Release tension to the belt tension handle (C) clockwise. Tighten the belt tension lock knobs (B).

ASSEMBLY INSTRUCTIONS

3. Choose the desired speed for your drilling operation, and move the belts (D) to the indicated position on the pulleys (E). Refer to the chart on the inside of the belt guard.
 4. Loosen the belt tension lock knobs and turn the belt tension handle (C) counterclockwise to apply tension to the belts.
 5. Tighten the belt tension lock knobs.
- NOTE:** The belt should deflect approximately 1/2" by applying finger pressure at the mid-point of the belt between the pulleys.
6. Close the belt guard.
 7. If the belt slips while drilling, readjust the belt tension.

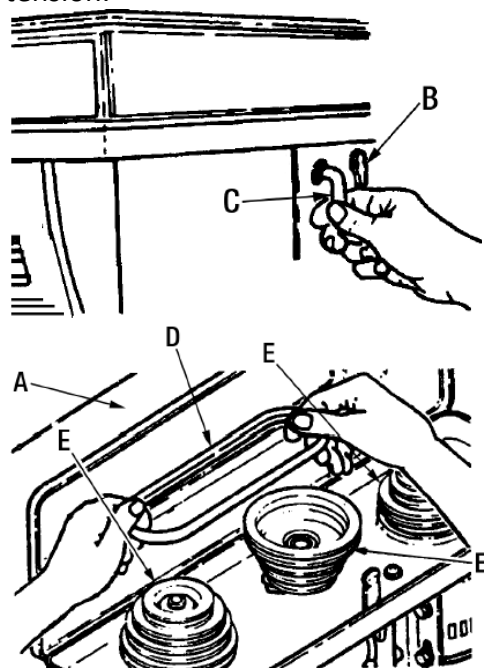

Installing drill bits

Insert the drill bit into the chuck far enough to obtain the maximum gripping of the chuck jaws. The chuck jaws are approximately 1" long. When using a small drill bit, do not insert it so far that the jaws touch the flutes (spiral grooves) of the bit.

Make sure the drill bit is centered in the chuck before tightening the chuck with the key. Tighten the drill bit well, so that it doesn't slip while drilling. Turn the chuck key clockwise to tighten, counter clockwise to loosen.

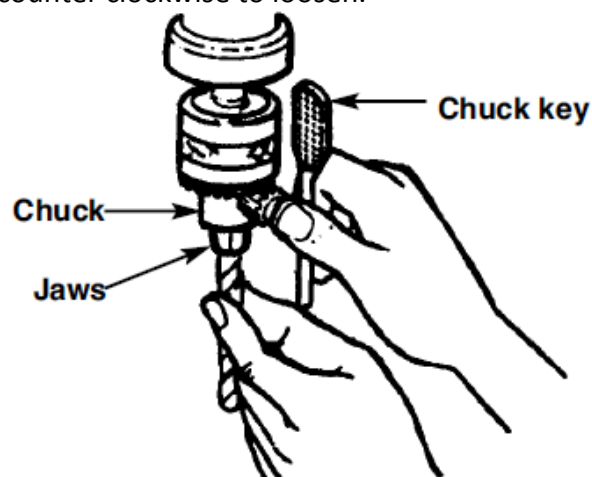

ADJUSTMENTS

Adjustments

WARNING! For your own safety, turn the switch OFF and remove the plug from the power source before making any adjustments. To avoid injury from thrown parts due to the spring release, follow instructions carefully and wear safety glasses.

Drilling to a specific depth

To drill a blind hole (not all the way through) to a given depth, proceed as follows.

1. Mark the depth of the hole on the workpiece.
 2. Loosen the depth scale lock knob (A) Fig.19.
 3. With the switch OFF, bring the drill bit down until the tip of the lips of the drill bit are even with the mark (B).
 4. Turn the depth scale (C) counterclockwise until it stops moving.
 5. Tighten the depth scale lock knob.
- The drill bit will stop at this depth until the depth scale is readjusted.

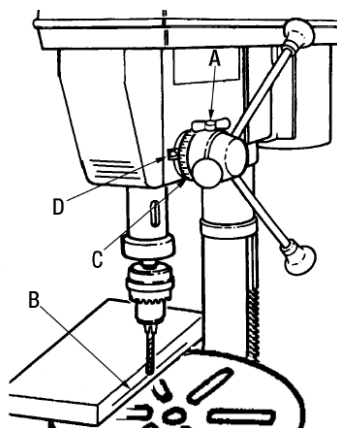

Another way-depth scale

1. With the power OFF, loosen the depth scale lock knob (A) Fig.19.
2. Place workpiece on table. Adjust table until the tip of the drill is just a little above the top of the workpiece.
3. Turn the depth scale (C) clockwise until the depth scale indicator (D) points to the desired drilling depth on the scale.

4. Tighten the depth scale lock knob.
5. The chuck or drill will now be stopped after traveling downward the distance selected on the depth scale.

Quill return spring

NOTE: The return spring tension is set at the factory and should not require further adjustment.

1. With the chuck at its highest possible position, turn the depth scale (C) clockwise until it stops and tighten the depth scale lock knob (A). This will prevent the quill from dropping while tensioning the spring.
2. Lower the table for additional clearance.
3. Work from the left side of the drill press.
4. Place screwdriver in the lower front notch (A) of the spring cap (B), and hold it in place while loosening and removing the outer nut (C) (only).
5. With screwdriver remaining in the notch, loosen inner nut (D) (approx. 1/8") until the notch disengages from the boss on the head. Do not remove this nut.
6. Carefully turn screwdriver counterclockwise and engage the next notch (E) in the boss. Do not remove screwdriver.
7. Tighten nut with wrench only enough to engage boss. Do not over tighten as this will restrict quill movement.
8. Check tension while turning feed handles.
9. If there is not enough tension on the spring, repeat steps 4-8 moving only one notch each time and checking tension after each repetition.

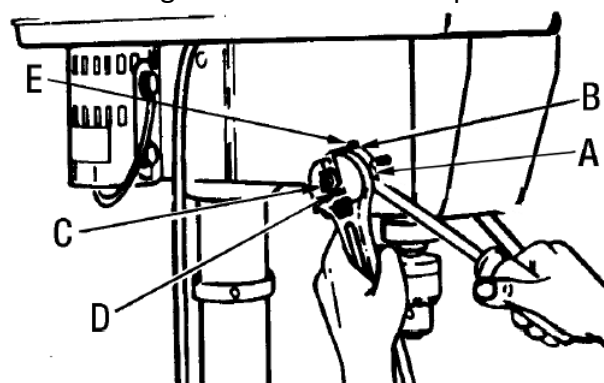

ADJUSTMENTS

Removing the chuck

1. Align key holes in spindle and quill (A) by rotating the chuck (C) by hand.
2. Insert drift key (B) into key holes in the quill.
3. Tap key drift key lightly until the chuck and arbour fall out of the spindle.

NOTE: Place one hand below the chuck to catch it when it falls out.

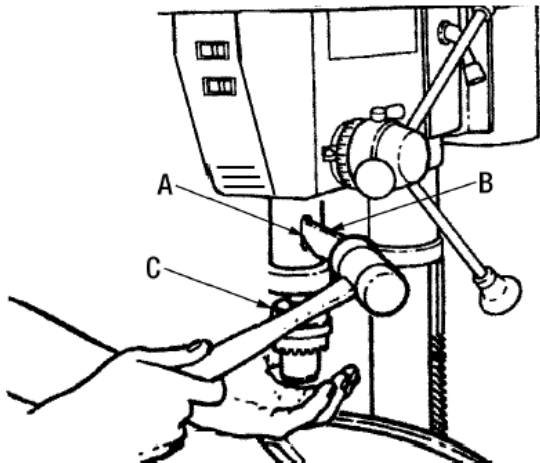

Adjusting the table square to the head

1. Insert a precision round steel rod (A) approximately 3" long into the chuck and tighten.
2. With the table (B) raised to working height and locked into position, place a combination square (C) flat on the table beside the rod.
3. If an adjustment is necessary, loosen the table bevel lock bolt (D) with an adjustable wrench and loosen the set screw (E) below the table bevel lock bolt. These adjustments are located under the table.
4. Align the table square to the rod by tilting the table.
5. Retighten the table bevel lock bolt. Retighten set screw.

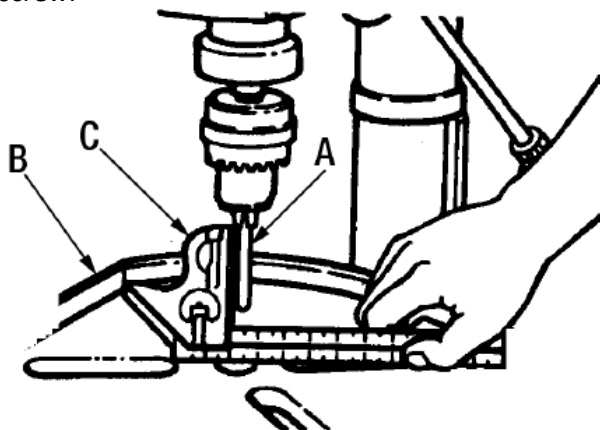

Tilting the table

To use the table in a bevel position, loosen the bevel lock bolt (D) with an adjustable wrench. Tilt the table to the desired angle by reading the bevel scale on the table support. Retighten the bevel lock bolt.

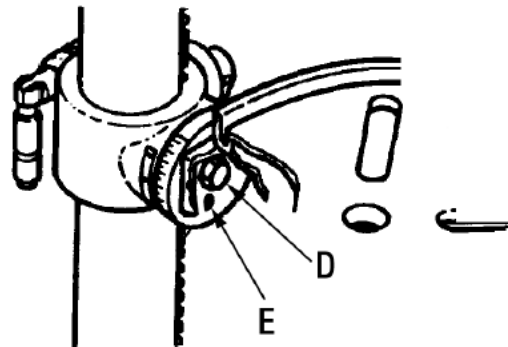

Feeding

Pull down the feed handles (A) with only enough effort to allow the drill to cut. Feeding too slowly might cause the drill to burn...feeding too rapidly might stop the motor...cause the belt or drill to slip...tear the workpiece loose or break the drill bit.

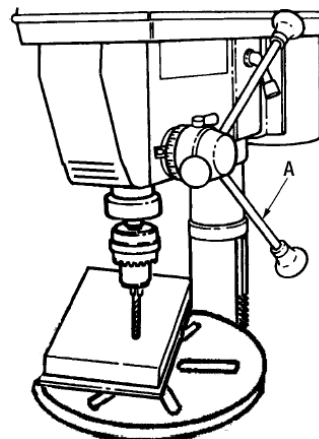

Hole location

Make an indentation in the workpiece where you want the to drill a hole using a centre punch or a sharp nail. Before turning the switch ON, bring the drill bit down to the workpiece, lining it up with the hole location.

ADJUSTMENTS

Positioning the table and workpiece

Lock the table to the column in a position so that the tip of the drill is just a little above the top of the workpiece. Always place a piece of back-up material (wood, plywood) on the table underneath the workpiece. This will prevent splintering or making a heavy burr on the underside of the workpiece as the drill breaks through. To keep the back-up material from spinning out of control, it must come in contact with the left side of the column, as illustrated in picture.

WARNING! To prevent the workpiece or the back-up material from being torn from your hand while drilling, position them against the left side of the column. If the workpiece or the back-up material are not long enough to reach the column, clamp them to the table. Failure to do this could result in personal injury.

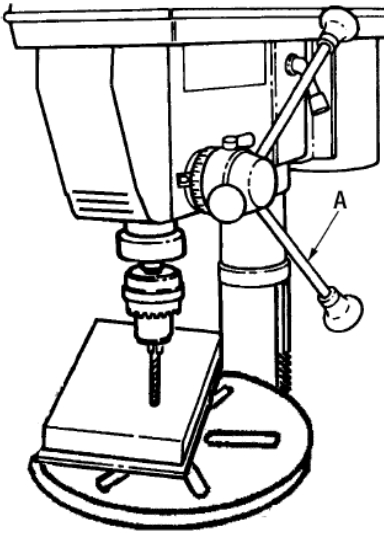

OPERATION & MAINTENANCE AND SERVICE

Operation

–Practise on waste material first to learn how to operating the machine.

–When drilling all the way through a piece of material, adjust the table so the drill is aligned with the centre of the table. Secure the work piece securely an unsecured work piece results in a rough drilling hole and increases the risk of the drill bit breaking.

–Use a piece of waste wood beneath your workpiece to reduce the risk of the work piece splinting and protect the drill tip.

–Use the lift handles to slowly bring the drill downwards and slowly feed the drill into the workpiece.

–Drill extra slowly when the drill bit is about to break through the workpiece to prevent splintering.

Switching on

Lift the safety stop case and engage the green start button.

Simply press the Red button to stop the machine

Switching on

Lift the safety stop case and engage the green start button.

Simply press the Red button to stop the machine

Cleaning And Maintenance

Before performing any work on the equipment, pull the power plug.

Regularly clean the ventilation slots, dust build up can damage the motor.

Grease every three months by turning the drill to maximum drill depth and greasing the shaft with oil.

No repairs should be carried out without first contacting the supplier as this will void your warranty.

Storage

thoroughly cleans the whole machine and accessories before storing to keep the machine in good running condition.

Store out of reach of children in a stable cool temperature dry place and avoid too high or too low temperatures.

MAINTENANCE AND SERVICE

| Trouble | Probable cause | Remedy |
|--|--|--|
| Noisy Operation | <ol style="list-style-type: none"> 1. Incorrect belt tension 2. Dry spindle 3. Loose spindle pulley 4. Loose motor pulley | <ol style="list-style-type: none"> 1. Adjust tension 2. Lubricate spindle 3. Tighten the retaining nut on the pulley as needed 4. Tighten the set screws which hold the pulleys in place |
| Drill Bit Burns | <ol style="list-style-type: none"> 1. Incorrect speed 2. Chips not coming out of the hole 3. Dull drill bit 4. Feeding too slow 5. Not lubricated | <ol style="list-style-type: none"> 1. Change the speed 2. Retract drill bit frequently to clear the chips 3. Resharpener the drill bit 4. Feeding too fast ...allow the drill bit to cut. 5. Lubricate the drill bit with cutting or motor oil. |
| Wood Splinters On Underside Of Workpiece. | <ol style="list-style-type: none"> 1. No "back up material" under workpiece | <ol style="list-style-type: none"> 1. Use "back up material" |
| Workpiece Torn Loose From Hand. | <ol style="list-style-type: none"> 1. Not supported or clamped properly | <ol style="list-style-type: none"> 1. Support the workpiece or clamp it. |
| Drill Bits Binds To Workpiece | <ol style="list-style-type: none"> 1. Workpiece is pinching the drill bit or there is an excessive feeding pressure. 2. Improper belt tension | <ol style="list-style-type: none"> 1. Support the workpiece or clamp it 2. Adjust the tension of the belt. |
| Excessive drill bit wobbling. | <ol style="list-style-type: none"> 1. Bent drill bit 2. Worn spindle bearings 3. Drill bit is not properly installed in the chuck 4. Chuck not properly installed. | <ol style="list-style-type: none"> 1. Use a straight drill bit. 2. Replace the bearings 3. Install drill bit properly 4. Install chuck properly |
| Quill returns too fast or too slow. | <ol style="list-style-type: none"> 1. Spring has improper tension. | <ol style="list-style-type: none"> 1. Adjust the spring tension. |
| Chuck will not stay attached to the spindle. It falls off when trying to install it. | <ol style="list-style-type: none"> 1. Dirt, grease or oil on the tapered inside surface of chuck or on the spindles tapered surface | <ol style="list-style-type: none"> 1. Using household detergent clean the tapered surface of the chuck and the spindle to remove the dirt, grease and oil. |

LUMBERJACK GUARANTEE

1. Guarantee

1.1 Lumberjack guarantees that for a period of 12 months from the date of purchase the components of qualifying products (see clauses 1.2.1 to 1.2.8) will be free from defects caused by faulty construction or manufacture.

1.2. During this period Lumberjack, will repair or replace free of charge any parts which are proved to be faulty in accordance with paragraph 1.1 providing that:

1.2.1 You follow the claims procedure set out in clause 2

1.2.2 Lumberjack and its authorised dealers are given reasonable opportunity after receiving notice of the claim to examine the product

1.2.3 If asked to do so by Lumberjack or its Authorised dealer, you return the product at your own cost to Lumberjack's or supplying Authorised Dealer's premises, for the examination to take place clearly stating the Returns Material Authorisation number given by Lumberjack or an Authorised Dealer.

1.2.4 The fault in question is not caused by industrial use, accidental damage, fair wear and tear, wilful damage, neglect, incorrect electrical connection, misuse, or alteration or repair of the product without approval.

1.2.5 The product has been used in a domestic environment only

1.2.6 The fault does not relate to consumable items such as blades, bearings, drive belts, or other wearing parts which can reasonably be expected to wear at different rates depending on usage.

1.2.7 The product has not been used for hire purposes.

1.2.8 The product has been purchased by you as the guarantee is not transferable from a private sale.

2. Claims Procedure

2.1 In the first instance please contact the Authorised Dealer who supplied the product to you. In our experience many initial problems with machines that are thought to be faulty due to faulty parts are actually solved by correct setting up or adjustment of the machine. A good Authorised Dealer should be able to resolve the majority of these issues much more quickly than processing a claim under the guarantee. If a return is requested by the Authorised Dealer or Lumberjack, you will be provided with a Returns Material Authorisation number which must be clearly stated on the returned package, and any accompanying correspondence. Failure to provide a Returns Material Authorisation number may result in item being refused delivery at Authorised Dealer.

2.2 Any issues with the product resulting in a potential claim under the guarantee must be reported to the Authorised Dealer from which it was purchased within 48 hours of Receipt.

2.3 If the Authorised Dealer who supplied the product to you has been unable to satisfy your query, any claims made under this Guarantee should be made directly to Lumberjack. The Claim itself should be made in a letter setting out the date and place of purchase, giving a brief explanation of the problem which has led to the claim. This letter should be then sent with proof

LUMBERJACK GUARANTEE

of purchase to Lumberjack. If you include a contact number with this it will speed your claim up.

2.4 Please note that it is essential that the letter of claim reaches Lumberjack on the last day of this Guarantee at the latest. Late claims will not be considered.

3. Limitation of Liability

3.1 We only supply products for domestic and private use. You agree not to use the product for any commercial, business or resale purposes and we have no liability to you for any loss of profit, loss of business, business interruption or loss of business opportunity.

3.2 This Guarantee does not confer any rights other than these expressly set out above and does not cover any claims for consequential loss or damage. This Guarantee is offered as an extra benefit and does not affect your statutory rights as a consumer.

4. Notice

This Guarantee applies to all product purchased from an Authorised Dealer of Lumberjack within the United Kingdom. Terms of Guarantee may vary in other countries.



CE DECLARATION OF CONFORMITY

TOOLSAVE

Unit C, Manders Ind. Est.,
Old Heath Road, Wolverhampton,
WV1 2RP.
Tel: 01902 450 470

Declares that the Bench Top Drill Press (DP20-1630F)
Is in compliance with the regulations included in the Directives:2006/95/EC

EC DECLARATION OF CONFORMITY

Certificate for EC-type examination delivered by Ente Certificazione Macchine srl, Via Cà Bella 243 -
Location Castello di Serravalle - 40053 Valsamoggia (Bo) ITALY (No.:2T160318.TTD0W34)

Person who declares: Bill Evans

CE

01.03.2017

The Director



Parts List

| No. | Description | No. | Description |
|------|-----------------------|------|-----------------------------|
| 1 | V-belt | 40 | Power cord |
| 2 | Pulley hex. nut | 43 | Motor mount bracket |
| 3 | Spindle pulley | 44 | Spring washer |
| 4 | Pulley insert | 45 | Hex. nut |
| 6 | Ball bearing | 46-2 | Motor |
| 7 | Spacer | 46-3 | Starting point (double) |
| 8 | Ball bearing | 47 | Hex. nut |
| 9 | Retaining ring shaft | 48 | Washer |
| 10 | Pan hd. screw | 49 | Motor cord |
| 11 | Cover knob | 50 | Hex. bolt |
| 12 | Ball bearing | 51 | Motor support rod |
| 13 | V-belt | 52 | Motor locking knob |
| 14 | Idler pulley | 53 | Belt tension handle |
| 15 | Idler pivot | 53-1 | Retaining ring/shaft |
| 16 | Pulley cover | 54 | Handle knob |
| 17 | Motor pulley | 55 | Feed handle rod |
| 18 | Set screw | 56 | Hub & pinion shaft assembly |
| 19 | Flange pan hd. screw | 57 | Set screw |
| 21 | Foam washer | 58 | Depth lock knob |
| 22 | Hex. key(3mm) | 60 | Stop pin (special) |
| 23 | Hex. key(5mm) | 61 | Scale sleeve |
| 26 | Set screw (special) | 62 | head |
| 27 | Special hex. nut | 63 | Tooth washer |
| 28 | Special hex. nut | 64 | Pan hd. screw |
| 29-1 | Spring & cap assembly | 65 | Switch box |
| 33 | Wire tie | 66 | Pan hd. screw |
| 36 | Cord clamp | 67 | Switch plate |
| 38 | Adjusting lever | 68 | Switch |
| 39 | Hex. bolt | 70 | Ball bearing |

Parts List

| No. | Description | No. | Description |
|-----|----------------------|------|--------------------|
| 71 | Spindle | 90 | Set screw |
| 72 | Chuck arbor | 91 | Hex. bolt |
| 73 | Chuck | 91-1 | Spring washer |
| 74 | Chuck key | 92 | Rack collar |
| 77 | Retaining ring/shaft | 94 | Column bracket |
| 78 | Ball bearing | 96 | Crank handle |
| 79 | Quill gasket | 97 | Base |
| 80 | Quill | 98 | Set screw |
| 81 | Drift key | 99 | Hex. bolt |
| 82 | Round table | 100 | Colum |
| 84 | Table arm w/scale | 101 | Rack |
| 85 | Table lock handle | 102 | Colum support |
| 86 | Elevation worm gear | 103 | Starting capacitor |
| 87 | Helical gear | 104 | Chuck guard |
| 88 | Bracket lock handle | 105 | Tapping screw |
| 89 | Gear pin | | |

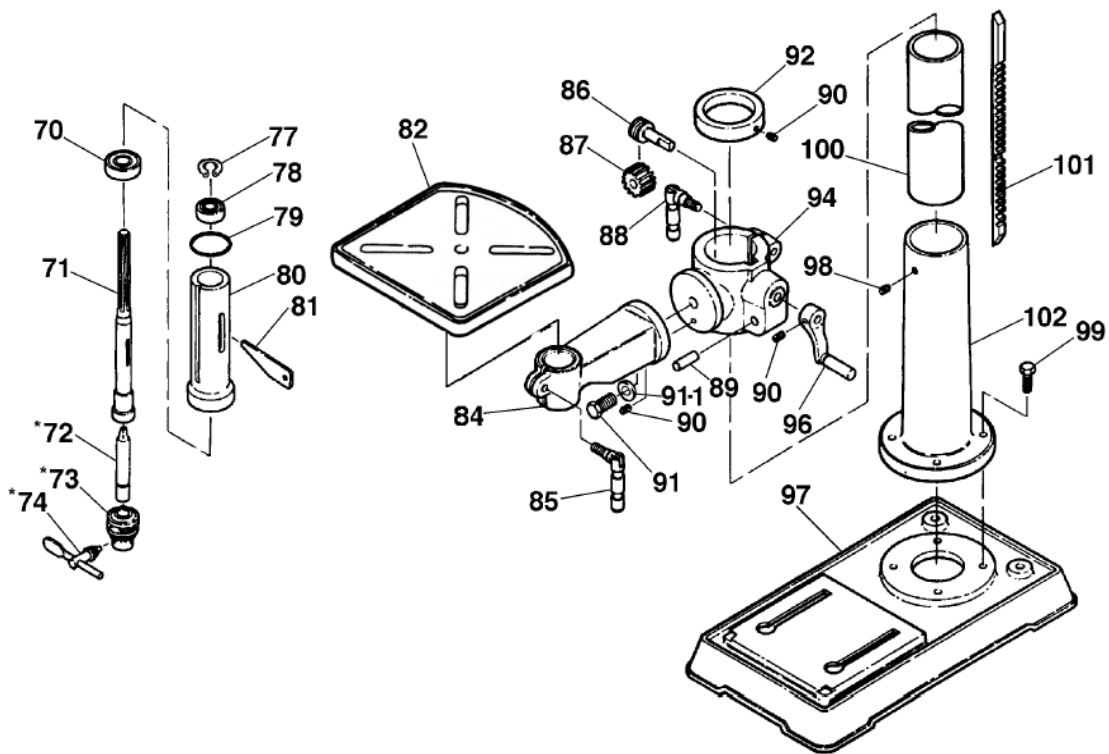

Parts Diagram

